

SERVOPLAN®

Precision Worm Gearboxes
for Servomotors

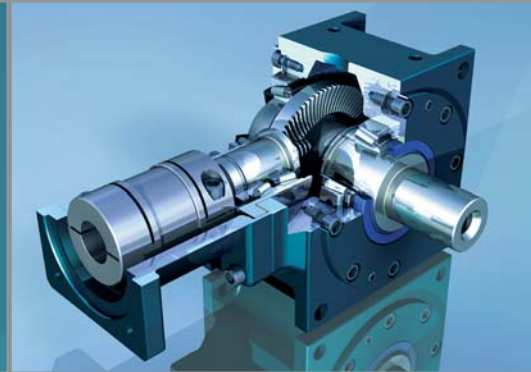
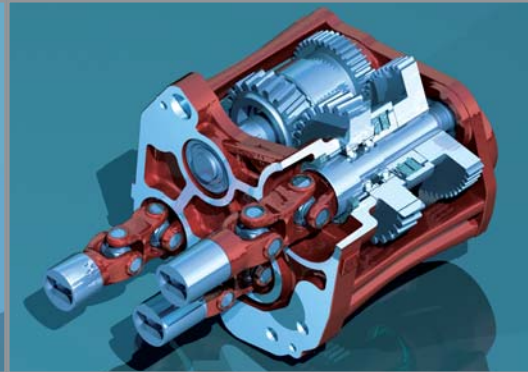
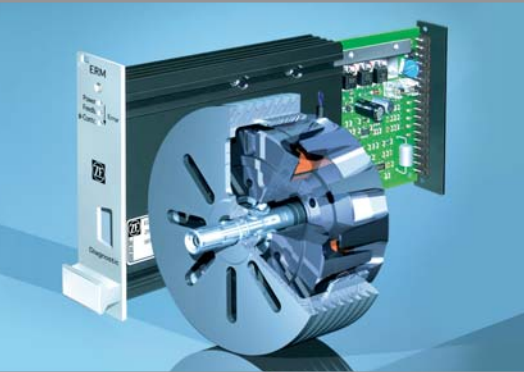
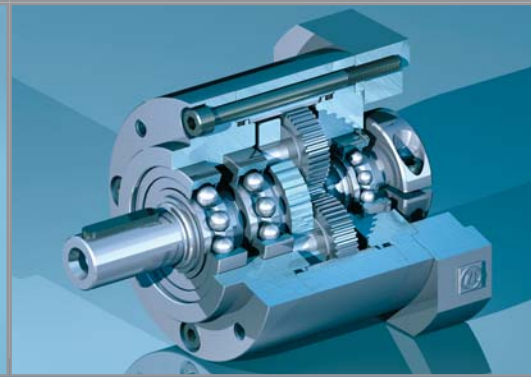
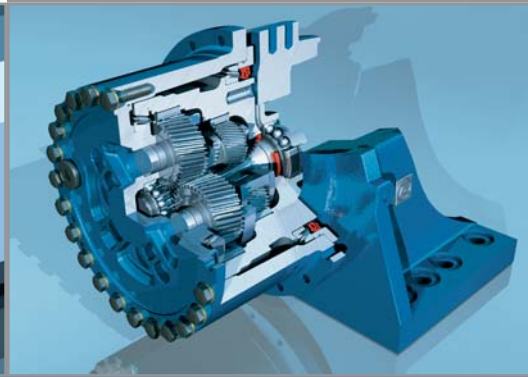
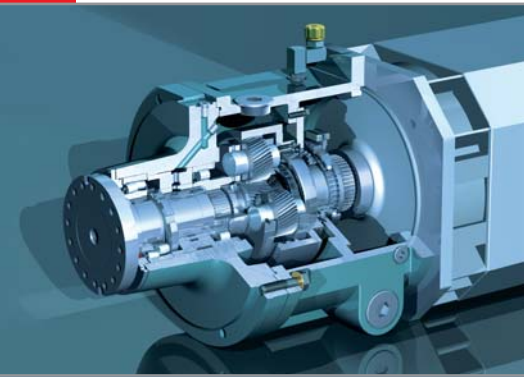
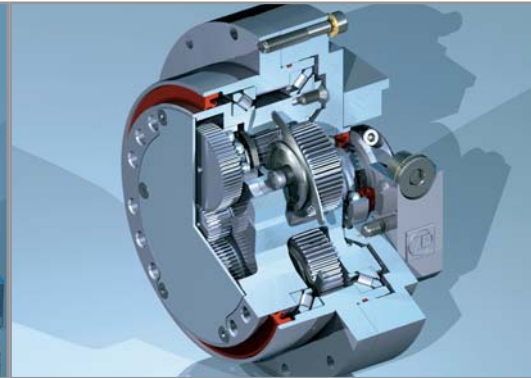
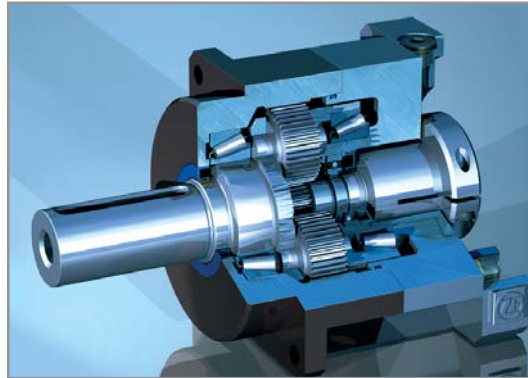

ZF-Duoplan 2K
Two-speed Gearboxes

ZF-Servoplan PG
Servogearboxes

ZF-Servoplan CG
Compact Gearboxes

ZF-Tiratron
Hysteresis Brakes

ZF-Ecolift
Elevator Gearboxes

ZF-Servoplan PGE
Servogearboxes Economy

Customer specific
Gearboxes

ZF-Servoplan WT
Right Angle Gearboxes



Servoplan SWG
Servogearboxes

Precision in movement

Our group has offered its customers a wide range of high quality power transmission components for a long period of time. Our extensive product portfolio includes gearboxes, brakes and clutches serving a variety of industries.

Our geared products include: in-line servo gearboxes (ZF-Servoplan PG and PGE), right angle servo gearboxes (ZF-Servoplan WT and Servoplan SWG) and compact servo gearboxes (ZF-Servoplan CG) serving, among others, the general automation, packaging, material handling, machine tool and robotics industries. Our innovative two-speed gearbox (ZF-Duoplan) was developed for main spindle drives in machine tools, and a high efficiency planetary gearbox was developed for elevators (ZF-Ecolift).

The innovative line of hysteresis brakes and clutches (ZF-Tiratron) offer non-contact, speed independent torque transmission for web control. Our electromagnetic brakes and clutches have set the standard in a variety of industries for multi disc, friction and toothed versions.

We also offer customer specific gearboxes for a variety of industries including printing and converting, as well as brakes and clutches for industries including exercise equipment, power tool and automotive.

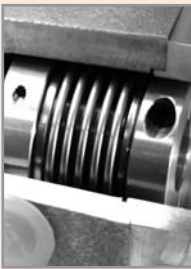

A new step in servogears:

SERVOPLAN SWG

3 Precision Levels:

High Precision: backlash ≤ 1 arcmin

Precision: backlash ≤ 3 arcmin

Standard: backlash ≤ 10 arcmin

4



Hollow shaft + servo kit



Dual output shaft + servo kit
(sizes 30-800 only)



Single output shaft + servo kit

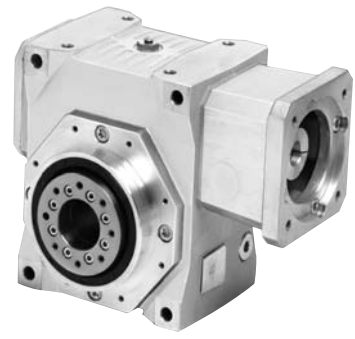

Robot flange output
(sizes 80 - 800 only)

1. **Computer optimized gear contact pattern:** less stress, longer life.
2. **Keyless connection:** reliable and backlash free connection with shrink disc.
3. **Servo Adaptation:** including high torsional stiffness coupling with steel bellows coupling + flange available for all existing servomotors.
4. **Oversized taper roller bearings:** provide very high permissible loads.
5. **Constant input bearings preload design:** 2 taper roller bearings + 1 floating ball bearing allowing temperature variations with same preload : higher input permissible speeds, longer life.
6. **Pinned and bound wheel ring:** 100 % stiff and reliable keyless connection, sizes 30-800. Centrifugally cast wheel ring sizes 1500-4800.
7. **Compact design, hardened aluminium-magnesium alloy:** lower weight, higher loads, sizes 30-800. Cast iron sizes 1500-4800.
8. **Life time:** 25000 hours.

SWG benefits

Low backlash

Space saving configuration: the right-angle design, more compact, is favorable in most cases.

Wormgear: low noise level (<55 dB), more important permissible overloads, higher torsional stiffness.

Maintenance free: life-lubricated unit with high performance polyglycol lubricant.

Unbeatable ratio of price to performance

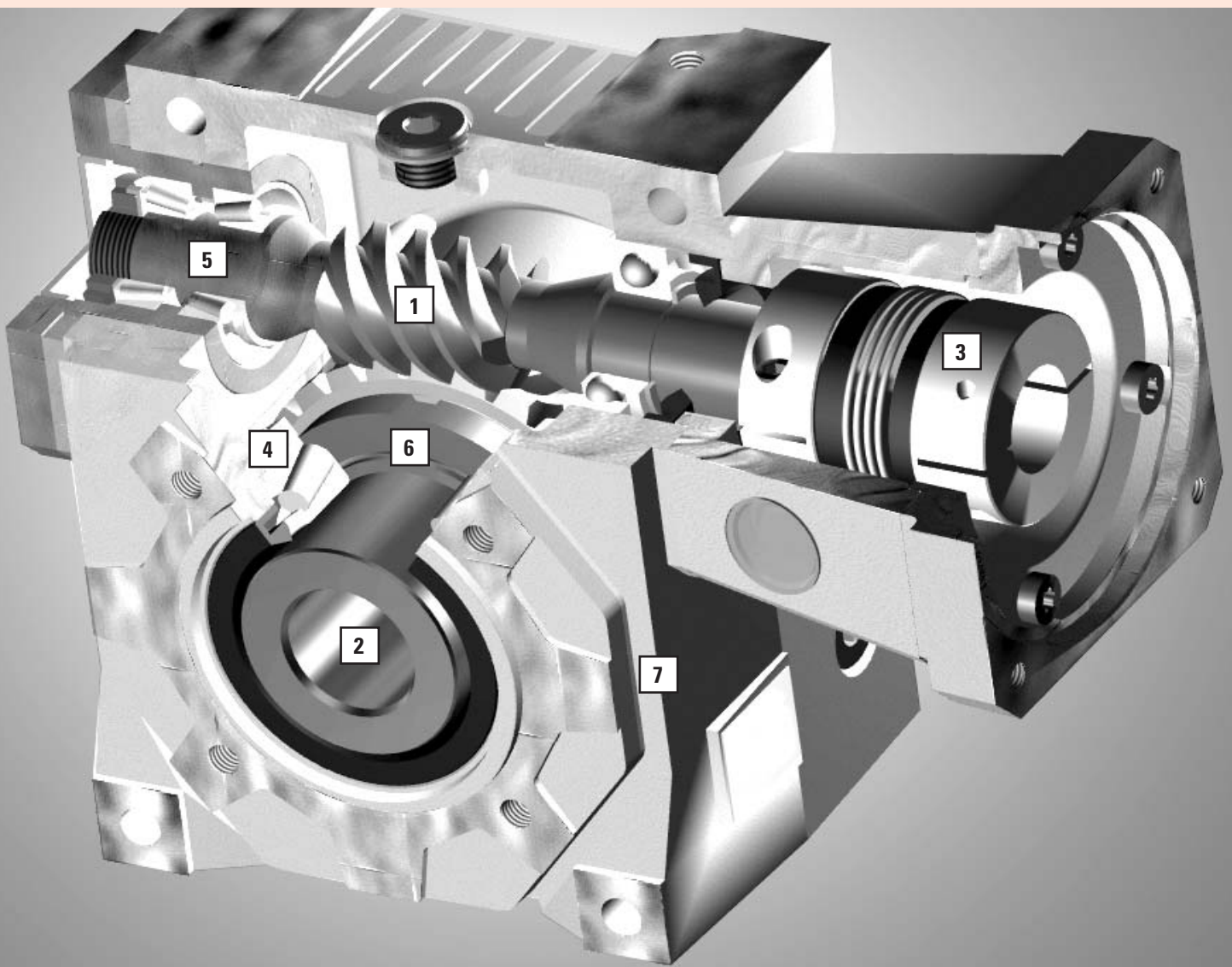

Technical Specifications

N1		6000			4000			3000			2000			1000			E-stop	C1f	ig	Et	Self Locking	Fr	Fa
i	Torque S5	η	Torque S1	Torque S5	η	Torque S1	Torque S5	η	Torque S1	Torque S5	η	Torque S1	Torque S5	η									
SWG 30	5.2:1	23	94	16	27	93	18	31	92	22	36	91	29	48	89	96	0.3	7.4×10^6	5		3800	2800	
	7.25:1	23	92	17	28	91	19	32	90	23	37	89	30	48	86	96	0.3	5.6×10^6	5		3800	2800	
	10.25:1	24	90	17	29	89	20	34	88	23	39	87	30	51	81	96	0.3	5×10^6	5		3800	2800	
	14.5:1	27	87	19	31	85	22	35	83	26	41	81	33	52	77	96	0.3	4.4×10^6	5		3800	2800	
	19.5:1	28	84	20	32	82	22	35	80	26	42	78	33	50	73	96	0.2	4.2×10^6	5		3800	2800	
	30:1	30	77	23	37	74	25	40	72	29	46	69	36	58	63	96	0.2	4×10^6	5		3800	2800	
	45:1	30	71	23	36	68	25	40	65	28	45	61	35	56	56	87	0.2	3.9×10^6	5	✓	3800	2800	
	60:1	30	65	22	34	62	24	37	59	27	41	55	34	50	50	73	0.1	3.1×10^6	5	✓	3800	2800	
	90:1	28	57	21	32	53	23	35	50	26	39	46	32	46	41	72	0.1	2.31×10^6	5	✓	3800	2800	

SWG 80	5.2:1	54	95	36	62	94	41	70	93	50	83	92	67	109	91	214	0.4	2.9×10^5	9		5800	4000
	7.25:1	59	94	42	71	93	48	80	92	57	93	91	76	121	89	214	0.4	2.2×10^5	9		5800	4000
	10.25:1	68	93	46	80	92	53	88	91	62	98	90	80	128	88	214	0.4	1.5×10^5	9		5800	4000
	14.5:1	69	90	52	83	88	59	94	87	68	109	86	88	141	82	214	0.4	1.4×10^5	9		5800	4000
	19.5:1	66	89	50	80	87	55	88	86	64	102	84	81	129	80	214	0.3	1×10^5	9		5800	4000
	30:1	74	83	55	88	80	61	98	78	70	112	76	88	141	71	214	0.3	1×10^5	9		5800	4000
	45:1	74	77	54	86	75	59	94	72	68	109	69	83	133	64	185	0.3	8.2×10^4	9	✓	5800	4000
	60:1	69	73	50	78	70	55	86	68	62	97	64	75	116	59	170	0.2	7.3×10^4	9	✓	5800	4000
	90:1	63	66	46	71	62	50	76	59	57	86	56	68	99	50	154	0.2	4.6×10^4	9	✓	5800	4000

SWG 120	5.2:1	85	95	60	103	94	68	116	94	82	137	93	111	181	91	307	0.6	7.5×10^4	20		7000	4800
	7.25:1	88	94	65	111	93	74	125	92	90	147	91	118	188	89	307	0.6	5.3×10^4	20		7000	4800
	10.25:1	102	92	76	132	90	87	145	89	103	165	88	133	206	85	307	0.6	4.5×10^4	20		7000	4800
	14.5:1	96	90	71	115	88	82	133	87	96	155	85	123	190	82	307	0.6	3.8×10^4	20		7000	4800
	19.5:1	101	88	77	123	87	87	139	85	101	162	83	128	205	80	307	0.4	3.1×10^4	20		7000	4800
	30:1	107	82	83	130	80	94	148	78	109	169	75	136	202	70	307	0.4	3.4×10^4	20		7000	4800
	45:1	110	77	83	130	74	93	145	72	106	163	69	131	202	63	307	0.4	2.8×10^4	20	✓	7000	4800
	60:1	110	73	82	128	69	91	141	67	103	158	63	126	194	58	286	0.3	2.6×10^4	20	✓	7000	4800
	90:1	102	65	76	117	62	82	125	59	94	142	55	113	164	49	263	0.3	1.2×10^4	20	✓	7000	4800

SWG 190	5.2:1	128	95	90	153	95	105	179	94	126	210	93	169	275	91	497	0.8	1.6×10^4	36		8800	8500
	7.25:1	123	95	91	155	94	103	174	93	125	206	92	165	264	90	497	0.8	9×10^3	36		8800	8500
	10.25:1	134	94	103	169	93	118	194	92	141	231	91	181	290	89	497	0.8	8×10^3	36		8800	8500
	14.5:1	146	91	110	179	90	128	207	89	149	240	87	191	293	84	497	0.8	6.9×10^3	36		8800	8500
	19.5:1	155	90	119	190	88	135	215	87	156	250	85	199	318	82	497	0.5	5.5×10^3	36		8800	8500
	30:1	179	84	138	218	82	155	245	80	179	281	78	223	335	73	497	0.5	5.9×10^3	36	✓	8800	8500
	45:1	163	80	123	193	77	137	214	75	156	239	72	193	287	67	403	0.5	5×10^3	36	✓	8800	8500
	60:1	162	76	121	189	73	134	205	71	151	233	67	186	288	62	404	0.4	4.7×10^3	36	✓	8800	8500
	90:1	149	68	110	169	65	121	184	63	137	207	59	166	241	53	368	0.4	3.2×10^3	36	✓	8800	8500

SWG 260	5.2:1	213	96	147	252	95	174	296	94	209	349	94	282	459	92	834	1	3.7×10^4	50		10500	10500
	7.25:1	190	95	139	236	94	161	270	93	196	321	92	256	409	90	834	1	2.5×10^4	50		10500	10500
	10.25:1	187	94	146	234	93	168	269	92	204	326	91	261	418	88	834	1	2.2×10^4	50		10500	10500
	14.5:1	237	91	170	276	90	195	315	88	234	376	87	298	460	84	834	1	1.9×10^4	50		10500	10500
	19.5:1	228	89	168	270	88	194	310	87	227	362	85	288	434	81	834	0.6	1.5×10^4	50		10500	10500
	30:1	252	86	186	294	84	212	334	82	248	386	80	309	460	75	834	0.6	1.6×10^4	50	✓	10500	10500
	45:1	243	79	190	299	76	212	331	74	244	383	71	301	472	65	718	0.6	1.4×10^4	50	✓	10500	10500
	60:1	225	75	175	272	72	195	300	69	221	334	66	272	395	60	657	0.5	1.3×10^4	50	✓	10500	10500
	90:1	218	68	167	257	64	184	280	62	209	316	57	255	370	52	625	0.5	8×10^3	50	✓	10500	10500

SWG 500	5.2:1	332	96	227	387	95	271	460	95	327	546	94	445	725	92	1543	1.5	8.5×10^4	75		15800	13000
	7.25:1	376	95	263	460	95	306	490	95	373	597	94	490	784	92	1543	1.5	6×10^4	75		15800	13000
	10.25:1	391	95	273	478	94	314	528	93	383	627	92	488	781	90	1543	1.5	3.8×10^4	75		15800	13000
	14.5:1	379	92	272	444	91	314	504	90	380	612	88	486	748	85	1543	1.5	3.2×10^4	75		15800	13000
	19.5:1	429	91	318	506	90	367	584	88	431	685	87	544	865	84	1543	0.8	2.5×10^4	75		15800	13000
	30:1	433	86	316	500	84	362	572	82	424	661	80	531	792	75	1543	0.8	2.6×10^4	75	✓	15800	13000
	45:1	454	83	343	538	80	385	599	79	441	674	76	546	811	71	1255	0.8	1.9×10^4	75	✓	15800	13000
	60:1	432	80	328	512	77	364	559	75	412	622	72	507	761	67	1230	0.5	1.7×10^4	75	✓	15800	13000
	90:1	394	74	298	459	70	332	505	68	372	562	64	460	667	59	1114	0.5	1×10^4	75	✓	15800	13000

SWG 800	5.2:1	567	96	390	666	95	458	779	95	561	937	94	760	1239	92	2289	2	$1.85 \times $
----------------	--------------	-----	----	-----	-----	----	-----	-----	----	-----	-----	----	-----	------	----	------	---	----------------

N1		6000			4000			3000			2000			1000			E-stop	ig	Self Locking	Fr	Fa	Cff
i	Torque S5	η	Torque S1	Torque S5	η	Torque S1	Torque S5	η	Torque S1	Torque S5	η	Torque S1	Torque S5	η								
SWG 1500	5.125:1	792	97	609	1005	96	716	1181	96	884	1459	95	1217	2008	94	3767	50		13600	12000	2.5	
	7.2:1	840	97	632	1043	96	742	1224	95	907	1497	95	1208	1993	93	3767	38		15000	15000	2.5	
	10.25:1	832	96	622	1026	95	725	1196	95	887	1464	94	1147	1893	92	3767	30.5		16700	18000	2.5	
	15.25:1	726	94	542	894	93	625	1031	92	759	1252	91	972	1604	89	3342	25		18900	22000	2.5	
	20.5:1	1026	93	759	1252	92	877	1447	91	1043	1721	89	1320	2178	87	3767	23.4		20600	22000	1.3	
	29.5:1	869	90	634	1046	88	731	1206	87	861	1421	85	1079	1780	81	3295	23.15		22900	22000	1.3	
	45:1	1142	86	833	1374	84	952	1571	82	1104	1822	80	1369	2259	75	3767	21	✓	26000	22000	1.3	
	60:1	980	82	713	1176	79	815	1345	77	929	1533	74	1150	1898	69	2937	20	✓	28000	22000	1	
	90:1	825	74	598	987	71	680	1122	68	779	1285	64	960	1584	58	2502	19	✓	32000	22000	1	

SWG 2500	5.125:1	1450	97	1128	1861	97	1324	2185	96	1648	2719	96	2334	3851	94	7251	120		17800	15000	3.5
	7.2:1	1411	97	1092	1802	96	1266	2089	96	1569	2589	95	2151	3549	94	7251	77		19700	19000	3.5
	10.25:1	1513	96	1161	1916	96	1346	2221	95	1650	2723	94	2215	3655	93	7251	63		21900	24000	3.5
	15.25:1	1333	95	1030	1700	94	1177	1942	93	1443	2381	92	1896	3128	90	5572	52.7		24700	29000	3.5
	20.5:1	1775	94	1338	2208	93	1530	2525	92	1856	3062	90	2392	3947	88	7251	51.5		27000	34000	1.7
	29.5:1	1492	91	1111	1833	89	1264	2086	88	1535	2533	86	1945	3209	83	6571	52.8		30000	34000	1.7
	45:1	2219	87	1630	2690	85	1858	3066	84	2211	3648	81	2765	4562	77	7251	46.5	✓	34100	34000	1.7
	60:1	1740	83	1272	2099	81	1439	2374	79	1723	2843	76	2127	3510	71	6331	40	✓	37200	34000	1.5
	90:1	1552	76	1123	1853	73	1261	2081	70	1489	2457	67	1842	3039	60	4933	38	✓	42000	34000	1.5

SWG 4800	5.125:1	2592	98	2008	3313	97	2392	3947	97	2954	4874	96	4208	6943	95	12826	287		37000	37500	4.5
	7.2:1	2721	97	2108	3478	97	2462	4062	96	3042	5019	96	4236	6989	94	12826	177		41000	44500	4.5
	10.25:1	2691	97	2071	3417	96	2408	3973	96	2946	4861	95	4007	6612	93	12826	143		46000	52600	4.5
	15.25:1	2346	95	1813	2991	94	2083	3437	94	2540	4191	93	3376	5570	91	12448	102		51800	63000	4.5
	20.5:1	3356	94	2551	4209	93	2909	4800	92	3538	5838	91	4590	7574	89	12826	96		56600	71000	2.2
	29.5:1	2841	92	2117	3493	90	2410	3977	89	2925	4826	87	3738	6168	84	12277	99		63000	71000	2.2
	45:1	3747	88	2775	4579	86	3154	5204	85	3788	6250	83	4747	7833	78	12826	82.5	✓	71700	71000	2.2
	60:1	3170	85	2325	3836	82	2636	4349	80	3159	5212	77	3928	6481	72	11674	71	✓	78000	71000	2
	90:1	2714	78	1985	3275	75	2228	3676	72	2641	4358	69	3316	5471	62	9323	69	✓	88000	71000	2

✓ Denotes self locking feature. However, this feature may be overcome. Therefore, it does not replace a brake.

Notes Concerning Efficiency

Efficiency values may be achieved after a minimum of 24 hours at full load operation (running-in-period).

Efficiency values are achieved only when gearbox operates at nominal torque. For gearbox operating below nominal torque, efficiency is lower.



SMOOTH SHAFT FOR SHRINK DISC (AVAILABLE FROM STOCK)

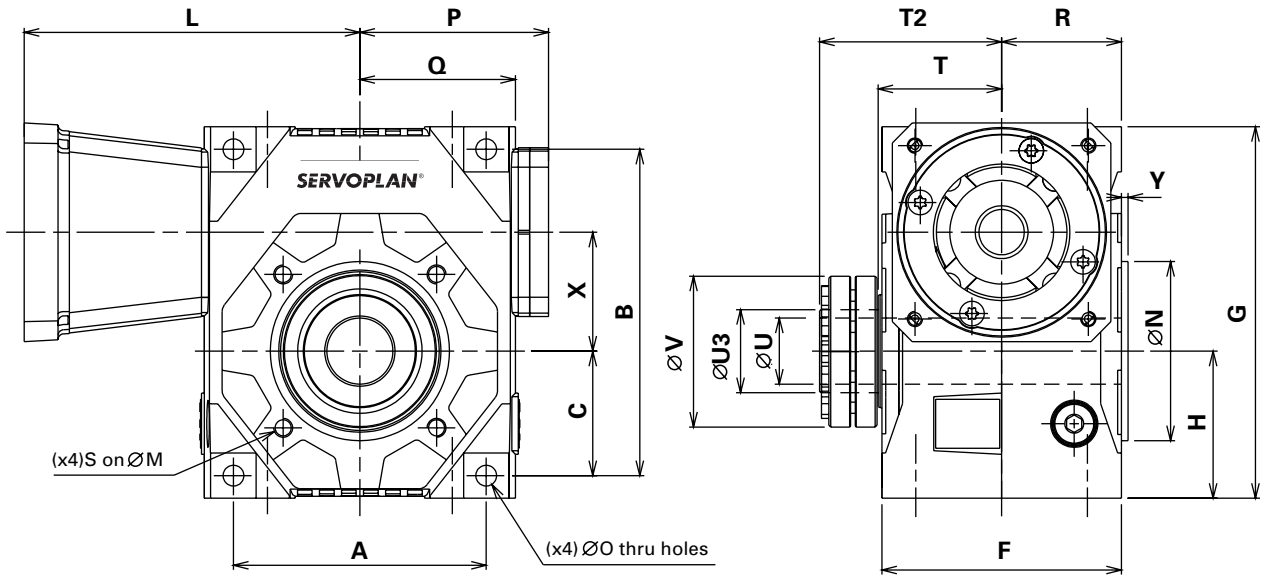

INPUT SHAFT VERSION

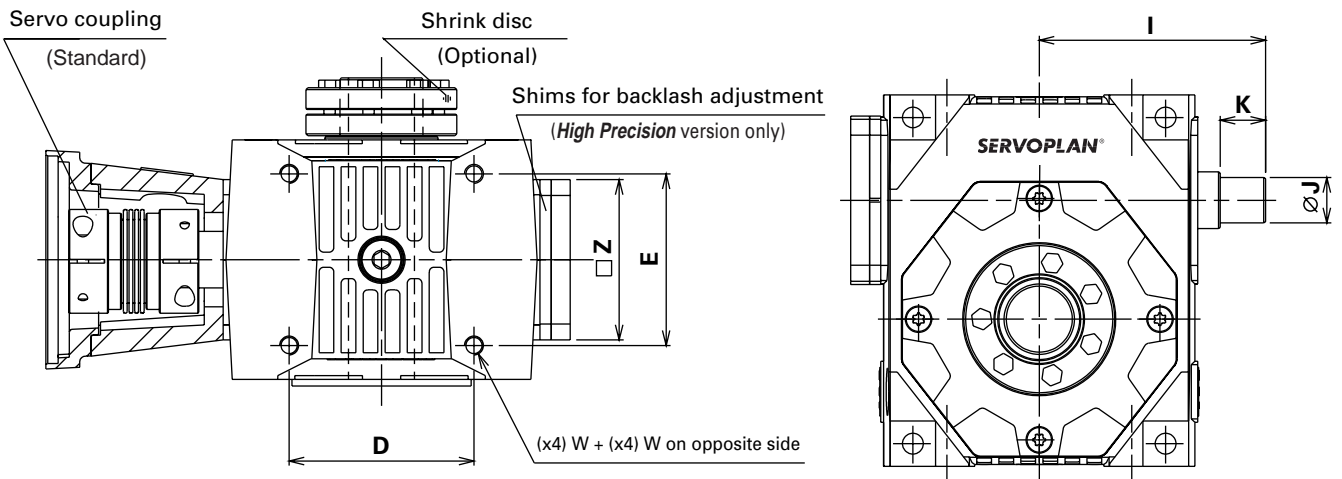

KEYWAYED HOLLOW SHAFT (NOT STOCKED)

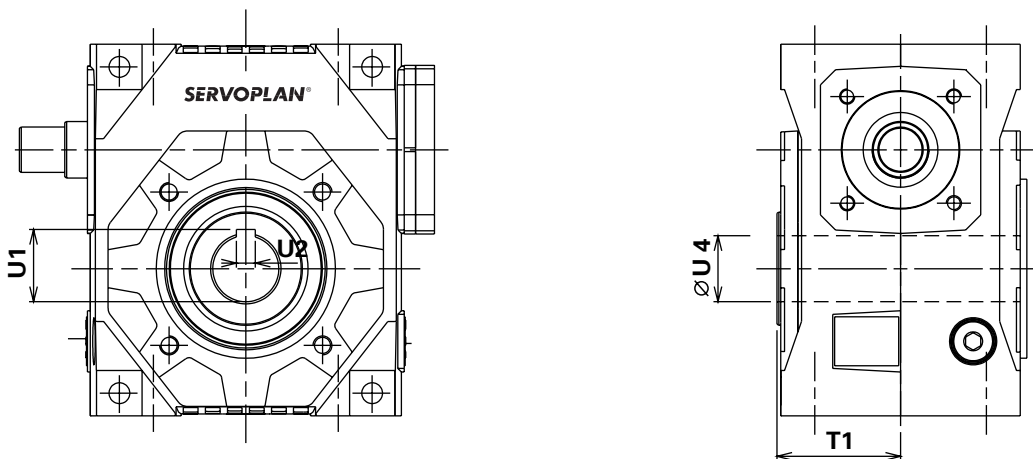

SWG	30	80	120	190	260	500	800
A	86	108	120	134	172	186	220
B	110	135	155	173	208	234	276
C	44.5	53	61	66	82	91	108
D	62	81	90	98	136	141	175
E	56	68	78	91	110	130	140
F	86	100	112	127	148	170	182
G	126	153	175	197	232	264	306
H	52.5	62	71	78	94	106	123
I (max)	80	97	107	120	145	159	182
I (min)	73.5	89.5	99	110	134	147	170
J (h6)	12	15	18	20	24	28	32
K	17	20	22	24	28	30	36
L	see page 19						
M	65	85	100	115	130	165	200
N (j7)	50	70	80	95	110	130	165
O	7	9	9	11	11	13	13
P (max)	70	83.5	91	101	124	136.5	152
Q	55	67.5	75	84	104	114.5	132
R	43	50	56	63.5	74	85	91
S	M6	M8	M8	M10	M10	M12	M12 (x8)
T	45	52	58	65.5	76	87	93
T1	45	52	58	65.5	76	87	93
T2	69	78	87	96.5	110	124	133
U (h7)	20	25	30	35	40	50	60
U4	16	25	30	35	40	50	60
U1	18.3	28.3	33.3	38.3	43.3	53.8	64.4
U2	5	8	8	10	12	14	18
U3	24	30	36	44	50	68	80
V	50	60	72	80	90	115	138
W	M6	M8	M8	M10	M10	M12	M12
X	35	45	55	63	75	90	110
Y	3	3	3.5	3.5	4	4	5
Z	58	75	75	85	95	115	115
Weight (kg)	3.4	6.2	8.5	13.9	20.5	32.5	46.5

Mounting Positions:

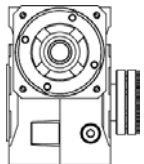
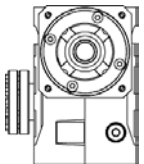
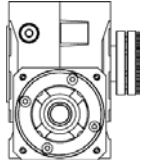
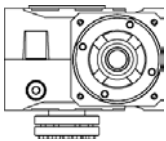
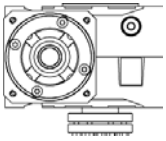
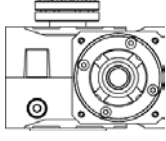
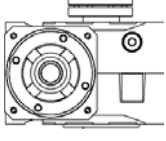
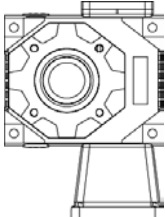
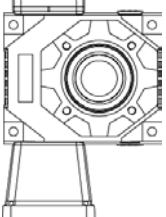
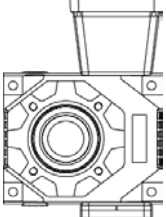
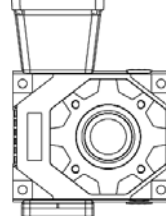
	1	2	3	4
H				
V				
F				

SMOOTH SHAFT FOR SHRINK DISC

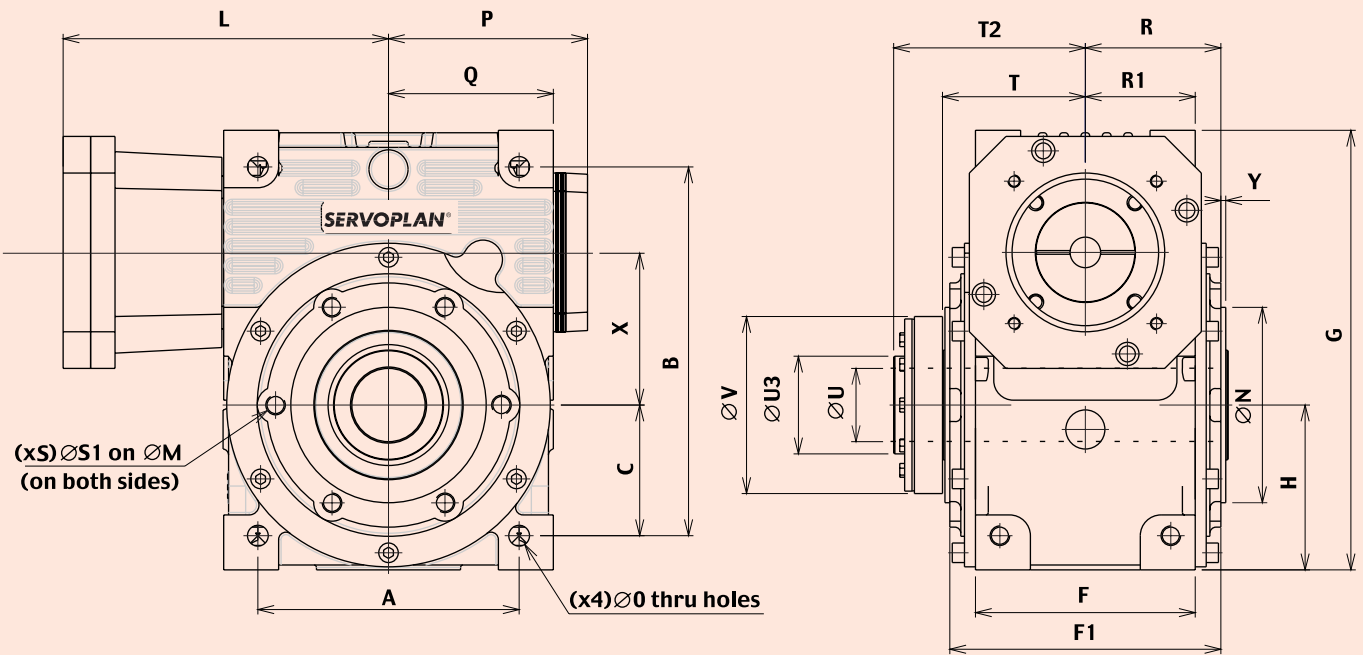

INPUT SHAFT VERSION

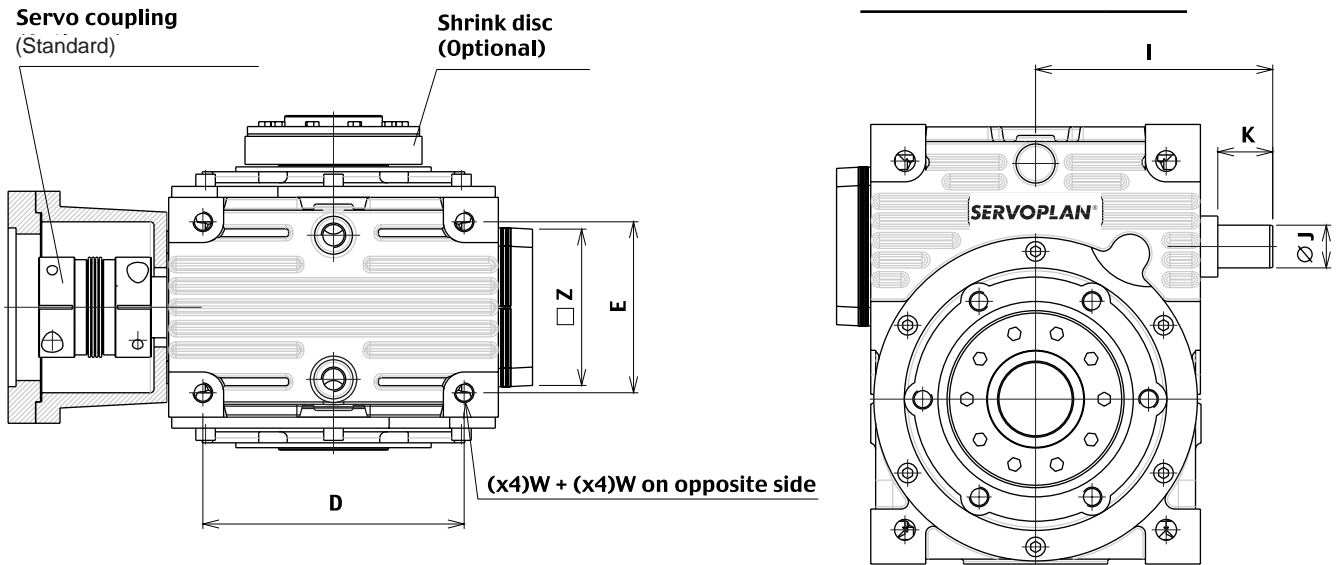

SWG	1500	2500	4800
A	214	284	342.5
B	302	377	483
C	107	142	171
D	214	284	342.5
E	140	150	224
F	180	198	288
F1	222	246	374
G	360	450	576
H	135	175	216
I	195	240	289
J	35	42	48
K	45	50	55
L	see page 21		
M	185	230	300
N	160	190	250
O	17	22	28
P	163	204	251
Q	135	175	216
R	111	123	187
R1	90	99	144
S	6	6	8
S1	M16	M20	M20
T	117	129	194
T2	157	177	264
U	65	75	100
U3	80	90	140
V	145	155	230
W	M16	M20	M20
X	125	160	200
Y	4	5	5
Z	130	140	180
Weight (kg)	108	172	370

Mounting Positions:

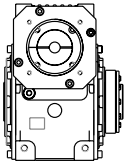
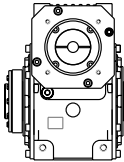
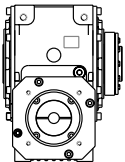
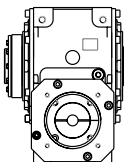
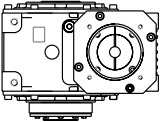
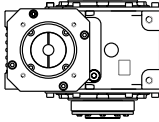
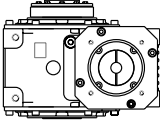
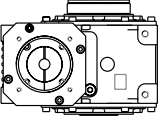
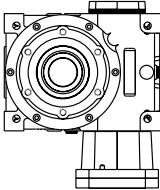
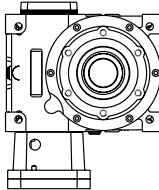
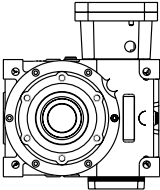
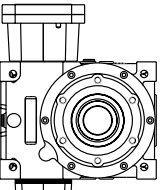
	1	2	3	4
H				
V				
F				

Note : Positions F are shown with shrink disc on back side.

SINGLE OUTPUT SHAFT

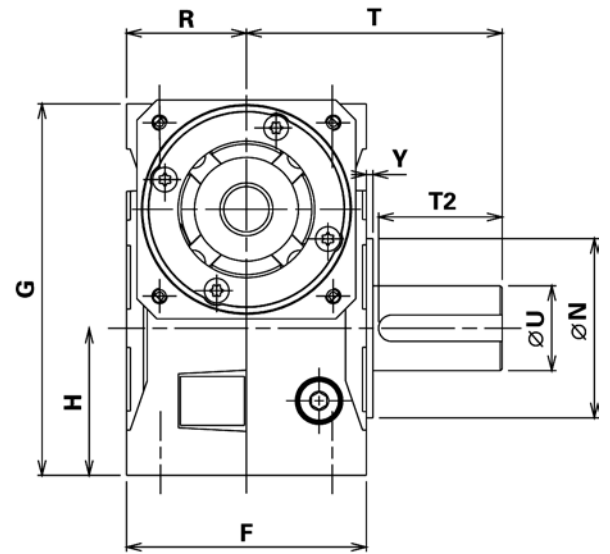
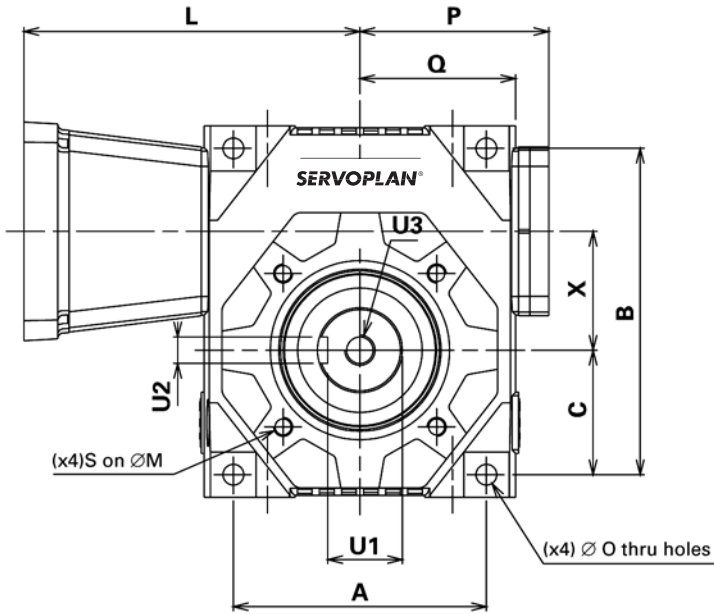

INPUT SHAFT VERSION

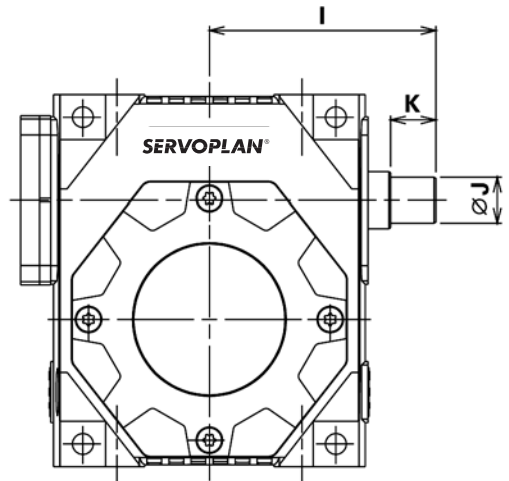
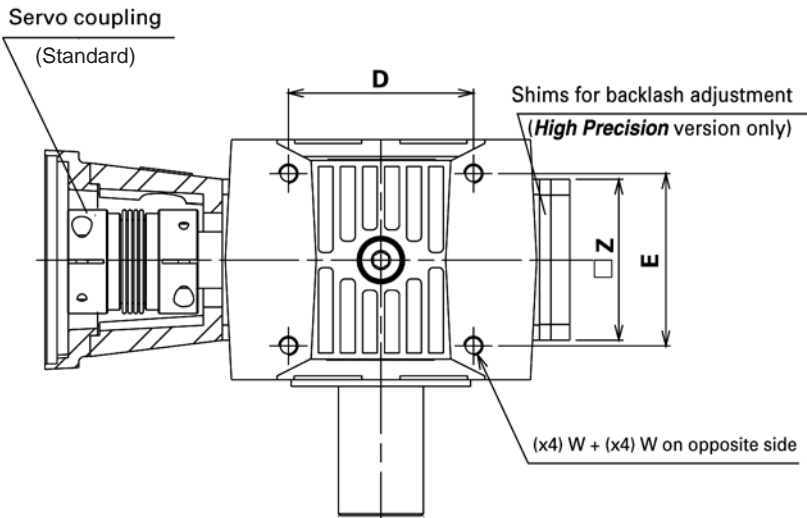

DUAL OUTPUT SHAFT

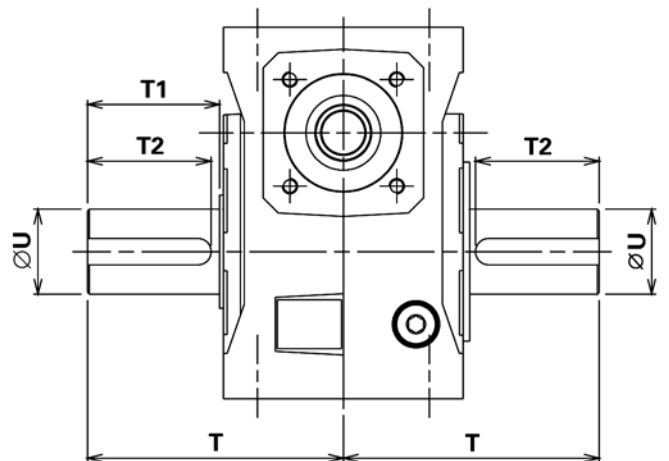
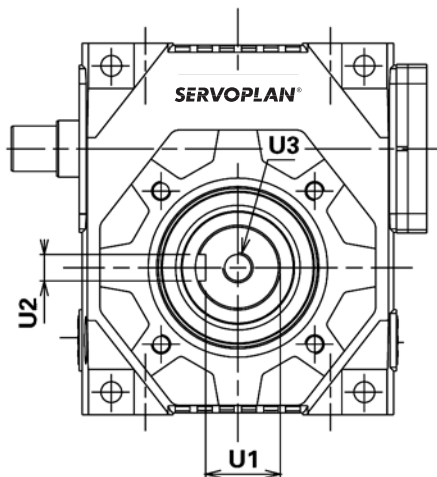

SWG	30	80	120	190	260	500	800
A	86	108	120	134	172	186	220
B	110	135	155	173	208	234	276
C	44.5	53	61	66	82	91	108
D	62	81	90	98	136	141	175
E	56	68	78	91	110	130	140
F	86	100	112	127	148	170	182
G	126	153	175	197	232	264	306
H	52.5	62	71	78	94	106	123
I (max)	80	97	107	120	145	159	182
I (min)	73.5	89.5	99	110	134	147	170
J (h6)	12	15	18	20	24	28	32
K	17	20	22	24	28	30	36
L	see page 19						
M	65	85	100	115	130	165	200
N (j7)	50	70	80	95	110	130	165
O	7	9	9	11	11	13	13
P (max)	70	83.5	91	101	124	136.5	152
Q	55	67.5	75	84	104	114.5	132
R	43	50	56	63.5	74	85	91
S	M6	M8	M8	M10	M10	M12	M12 (x8)
T	83	107	118	135.5	151	187	208
T1	38	55	60	70	75	100	115
T2	35	50	55	65	70	95.5	110
U (h6)	25	35	40	45	50	65	75
U1	21	30	35	39.5	44.5	58	67.5
U2	8	10	12	14	14	18	20
U3	M10	M12	M16	M16	M16	M20	M20
W	M6	M8	M8	M10	M10	M12	M12
X	35	45	55	63	75	90	110
Y	3	3	3.5	3.5	4	4	5
Z	58	75	75	85	95	115	115
WEIGHT (kg)	3.6	6.8	9.2	15.2	22.2	35.1	50.3

Mounting Positions:

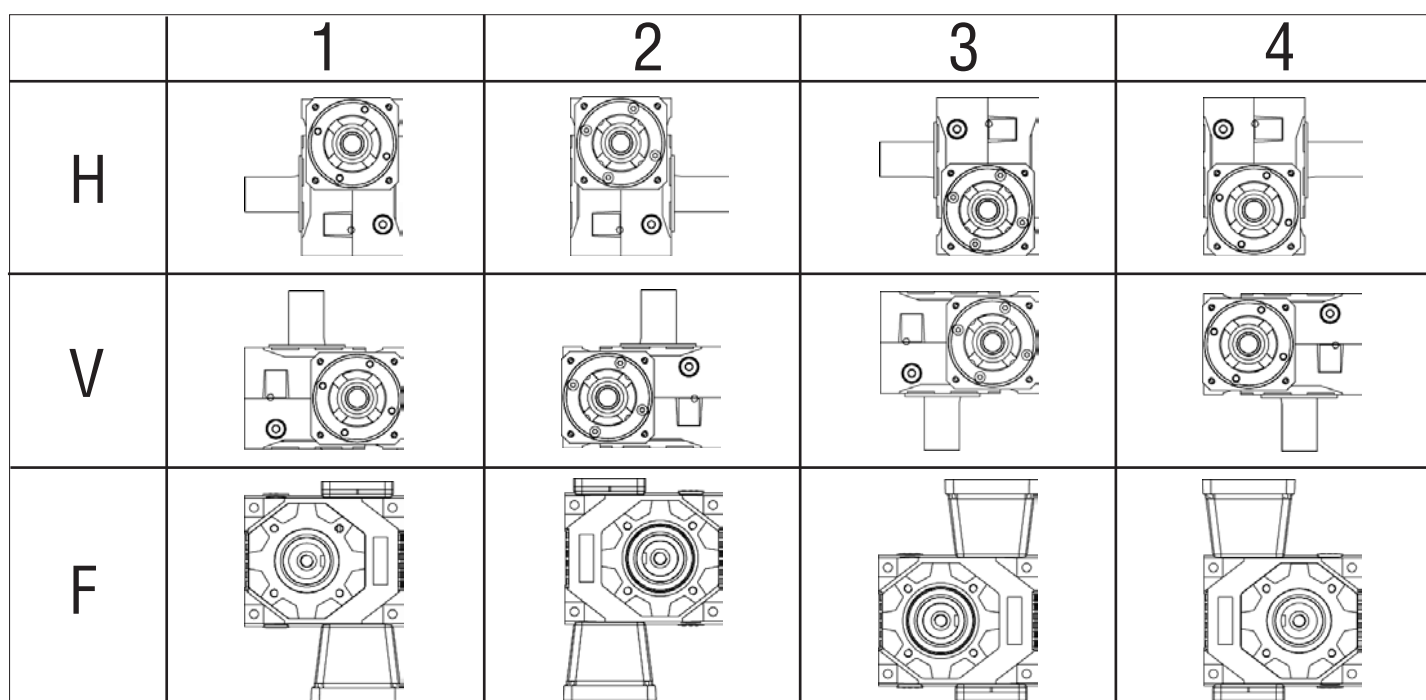

SINGLE OUTPUT SHAFT

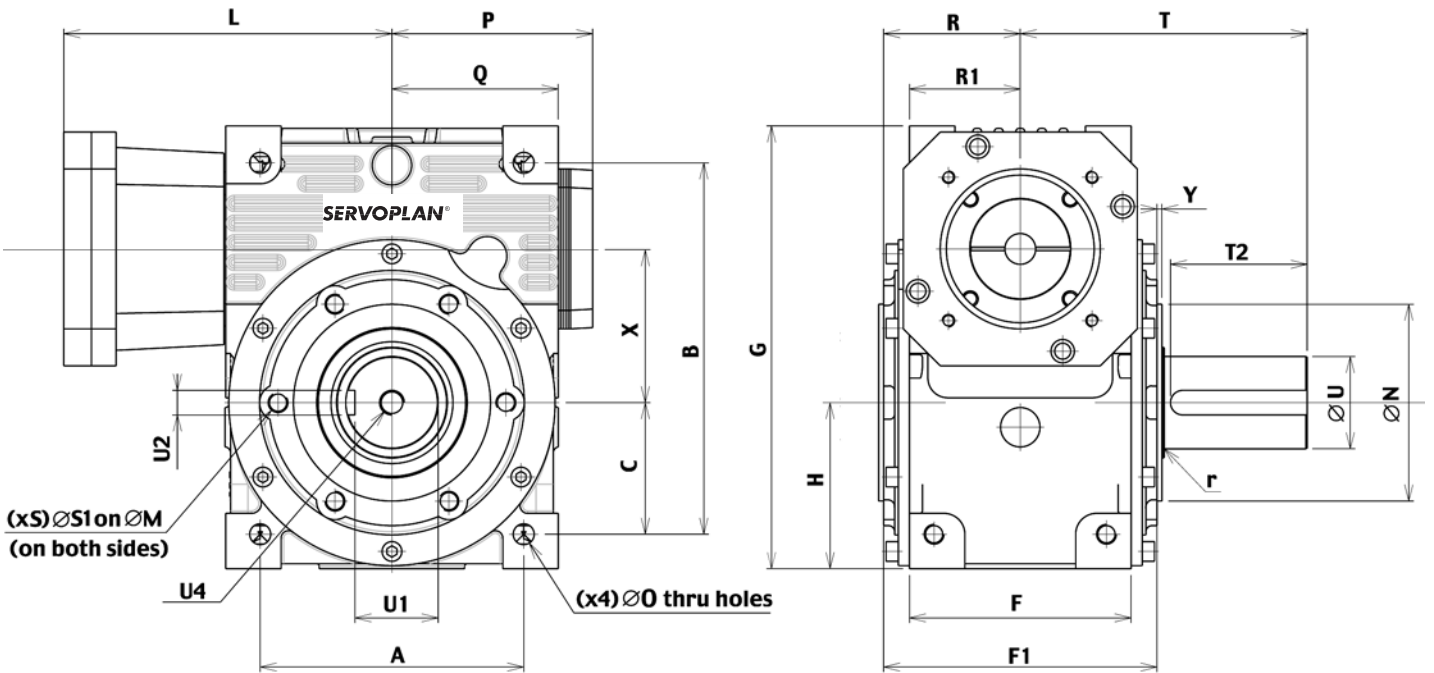

Servo coupling
(Standard)

Shims for backlash adjustment
(High Precision version only)

INPUT SHAFT VERSION

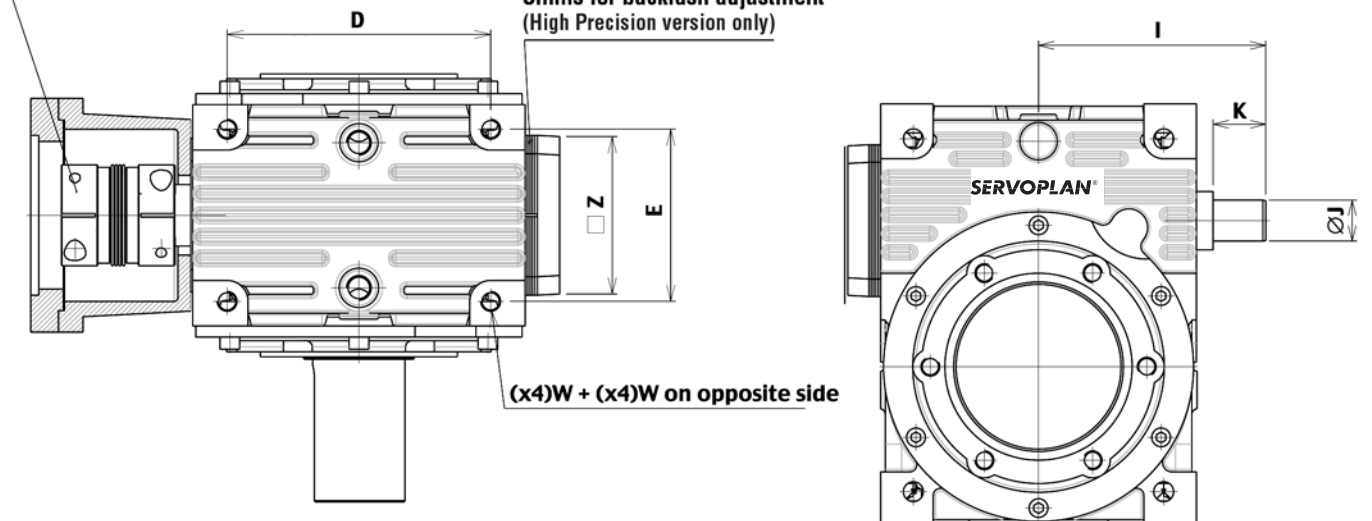

SWG	1500	2500	4800
A	214	284	342.5
B	302	377	483
C	107	142	171
D	214	284	342.5
E	140	150	224
F	180	198	288
F1	222	246	374
G	360	450	576
H	135	175	216
I	195	240	289
J	35	42	48
K	45	50	55
L	see page 21		
M	185	230	300
N	160	190	250
O	17	22	28
P	163	204	251
Q	135	175	216
r	3	3	5
R	111	123	187
R1	90	99	144
S	6	6	8
S1	M16	M20	M20
T	233	269	359
T2	111	135	164
U	75	90	120
U1	67.5	81	109
U2	20	25	32
U4	M20	M24	M24
W	M16	M20	M20
X	125	160	200
Y	4	5	5
Z	130	140	180
WEIGHT (kg)	116	184	400

Mounting Positions:

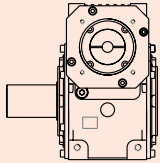
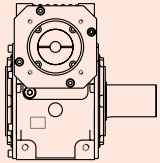
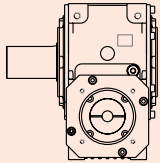
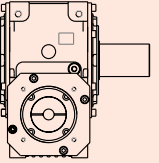
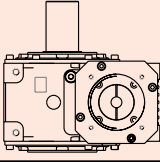
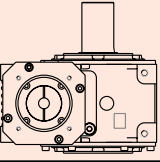
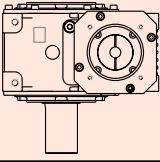
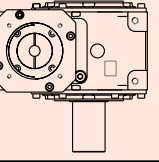
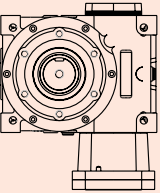
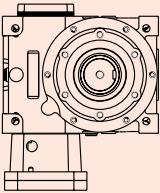
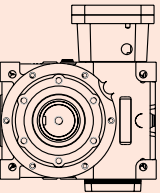
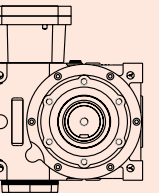
	1	2	3	4
H				
V				
F				

SWG - Robot Flange

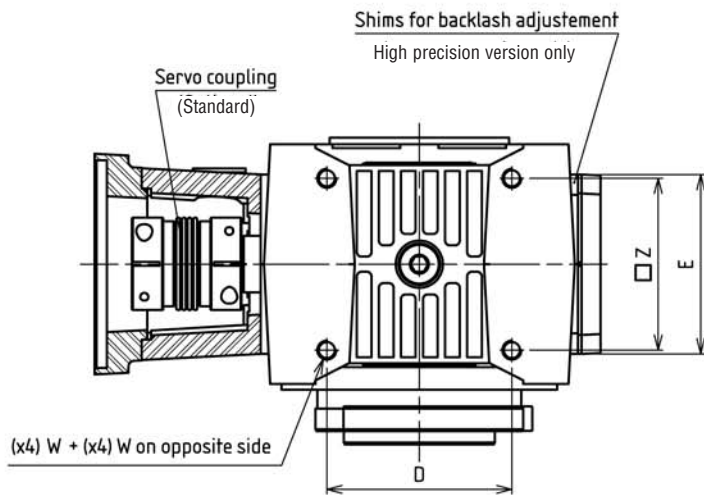
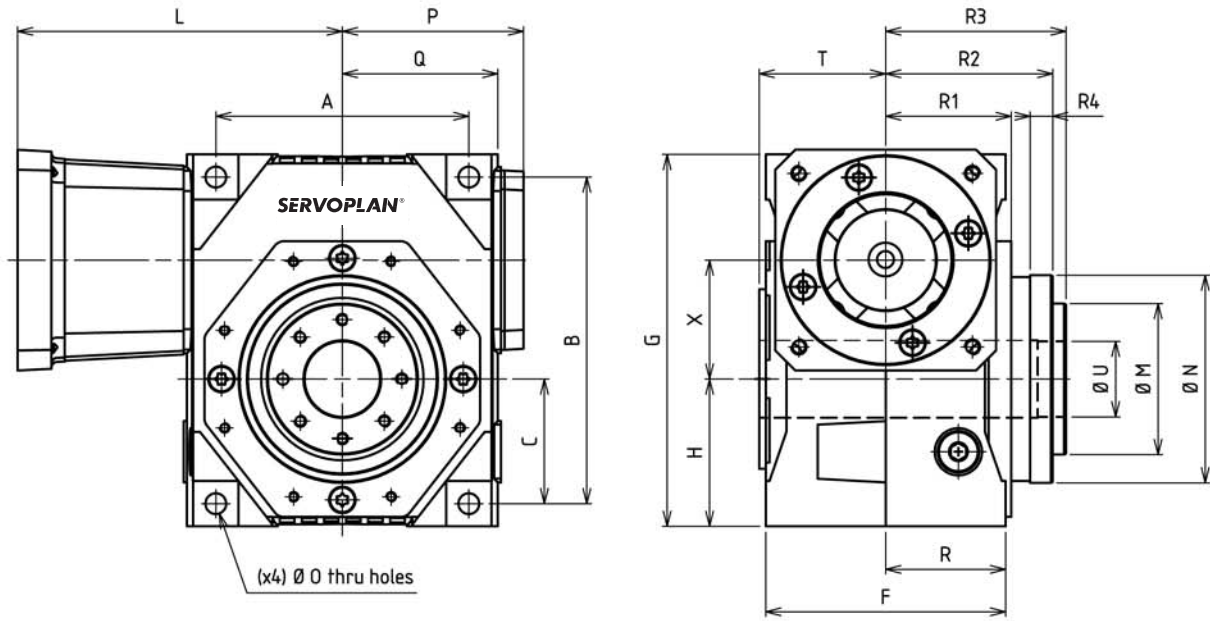

INPUT SHAFT VERSION

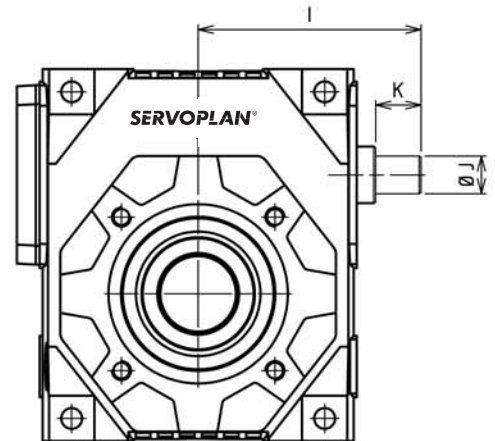

SIZES 80-120 and 190

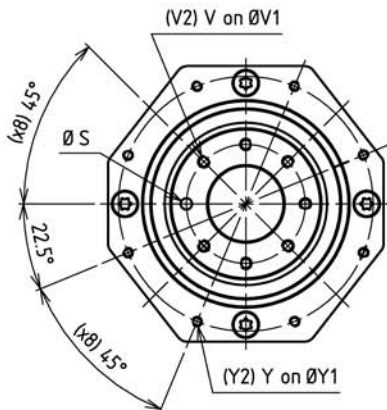

SIZES 260 and 500

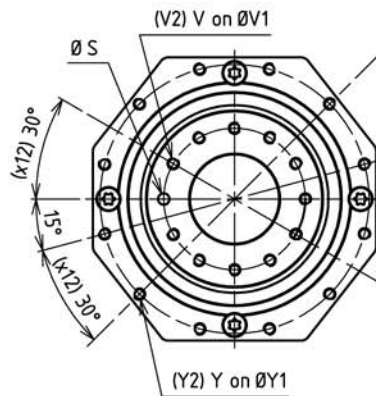

SIZE 800

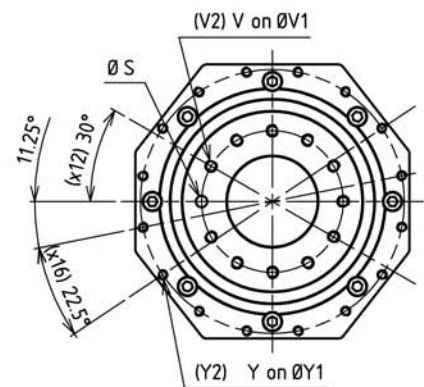

SWG Robot	80	120	190	260	500	800
A	108	120	134	172	186	220
B	135	155	173	208	234	276
C	53	61	66	82	1	108
D	81	90	98	136	141	175
E	68	78	91	110	130	140
F	100	112	127	148	170	182
G	153	175	197	232	264	306
H	62	71	78	94	106	123
I (max)	97	107	120	145	159	182
I (min)	89.5	99	110	134	147	170
J (h6)	15	18	20	24	28	32
K	20	22	24	28	30	36
L	see page 19					
M (h7)	50	63	80	100	125	160
N (h7)	80	90	110	140	65	200
O	9	9	11	11	13	13
P (max)	83.5	91	101	124	136.5	152
Q	67.5	75	84	104	114.5	132
R	50	56	63.5	74	85	91
R1	62	68	75.5	89	103	110
R2	82	91	97.5	120	139	150
R3	88	98	104.5	127	148	160
R4	10	12	12	15	18	22
S (h7)	6	6	6	8	8	10
T	53	59.5	67	78	89	96
U (h7)	25	30	35	40	50	60
V	M6	M6	M6	M8	M8	M10
V1	40	50	63	80	100	125
V2	7	7	7	11	11	11
W	M8	M8	M10	M10	M12	M12
X	45	55	63	75	90	110
Y	M5	M5	M5	M6	M8	M8
Y1	100	109	135	168	190	233
Y2	8	8	8	12	12	16
Z	75	75	85	95	115	115
Weight (kg)	6.2	8.5	13.9	20.5	32.5	46.5
Max. tilting torque (Nm)	250	450	780	1200	2150	3900
Tilting rigidity (Nm/armin)	330	520	580	800	1550	3050

Mounting Positions:

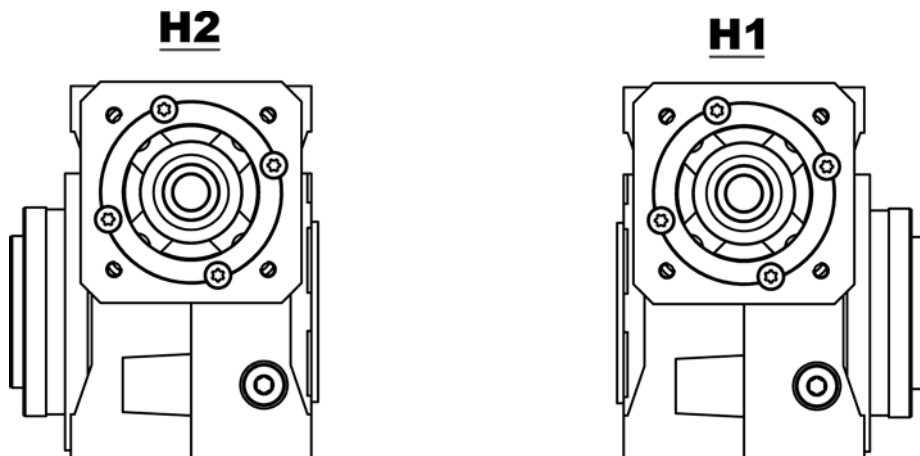

Servo Coupling

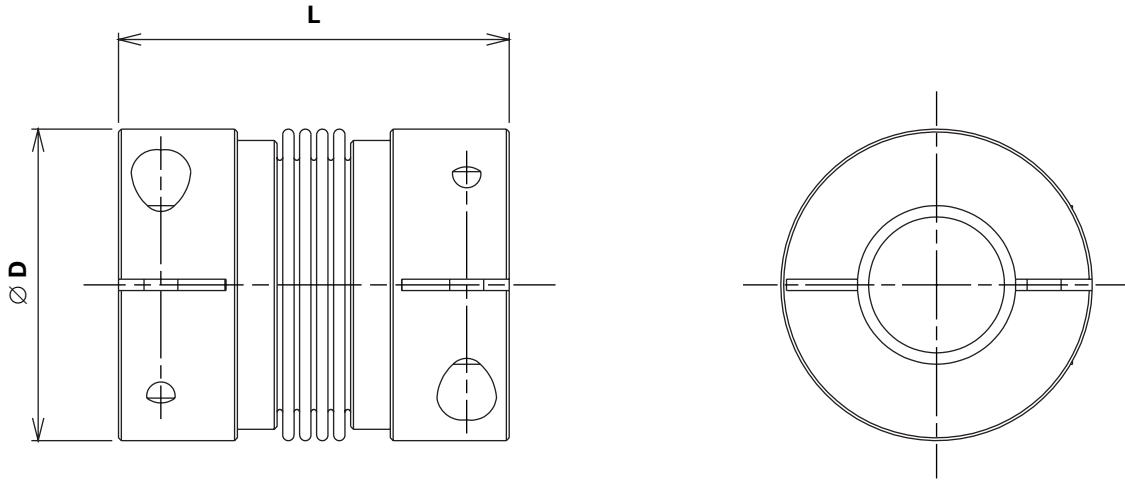

Coupling reference		005	010	015	030	060	080
Max. Ø servo shaft and SWG shaft	mm	Ø 16	Ø 24	Ø 28	Ø 32	Ø 35	Ø 42
Servo nominal torque	Nm	5	10	15	30	60	80
Servo peak torque	Nm	7.5	15	22.5	45	90	120
Ø D	mm	32	40	49	55	66	82
L	mm	40	44	58	68	79	92
Moment of inertia	10 ⁻³ kgm ²	0.01	0.02	0.06	0.12	0.20	0.60
Torsional stiffness	Nm/arcmin	2	2.6	6	11	21	23
Tightening torque of coupling screws	Nm	4	4.5	9	14	35	60

Specify the coupling reference and the motor shaft Ø when ordering.

Example : 15 Ø 14.

To calculate the total input inertia, add the coupling inertia to the gearbox inertia (page 6).

Servo Flange

Select the required flange on page 19.

If no flange can be found in the list, supply the dimensions from A to Z, or supply the servo reference when ordering.

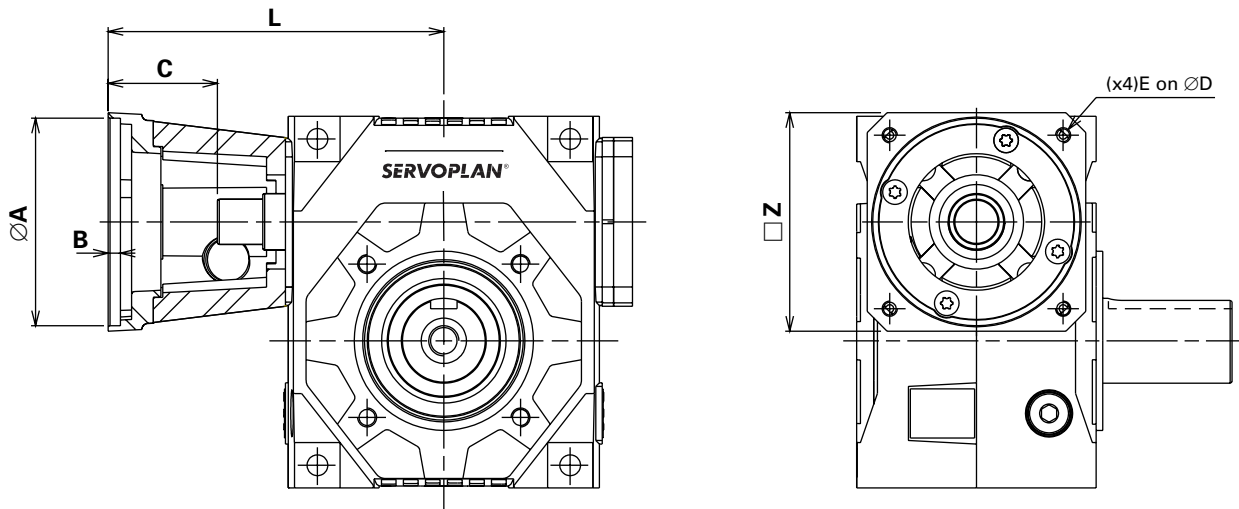

SWG	Reference	A	B	C min	D	E	L	Z
30	AA	40	4	31	63	M4	111	65
	AB	50	4	34	70	M4	114	65
	AC	60	4	34	75	M5	114	65
	AD	70	4	44	90	M5	124	90
	AE	50	4	34	95	M6	114	90
	AF	80	4	44	100	M6	124	90
	AG	95	5	44	115	M8	124	118
	AH	95	5	54	130	M8	134	118
	AI	110	5	54	130	M8	134	118
	AJ	110	6.5	64	145	M8	144	118
	80	AA	50	4	34.5	70	M4	131.5
AB		60	4	34.5	75	M5	131.5	81
AC		70	4	44.5	90	M5	141.5	91
AD		50	4	34.5	95	M6	131.5	91
AE		80	4	44.5	100	M6	141.5	91
AF		95	5	44.5	115	M8	141.5	115
AG		95	5	54.5	130	M8	151.5	115
AH		110	5	54.5	130	M8	151.5	115
AI		110	6.5	64.5	145	M8	161.5	140
AJ		110	6.5	54.5	165	M10	151.5	140
AK		130	6.5	54.5	165	M10	151.5	140
120	AA	50	4	35	70	M4	142	81
	AB	60	4	35	75	M5	142	81
	AC	70	4	45	90	M5	152	91
	AD	50	4	35	95	M6	142	91
	AE	80	4	45	100	M6	152	91
	AF	95	5	45	115	M8	152	115
	AG	95	5	55	130	M8	162	115
	AH	110	5	55	130	M8	162	115
	AI	110	6.5	65	145	M8	172	140
	AJ	110	6.5	55	165	M10	162	140
	AK	130	6.5	55	165	M10	162	140
190	AA	50	4	36	70	M4	156	102
	AB	60	4	36	75	M5	156	102
	AC	70	4	42	90	M5	162	102
	AD	80	4	42	100	M6	162	102
	AE	95	5	42	115	M8	162	115
	AF	95	5	52	130	M8	172	115
	AG	110	5	52	130	M8	172	115
	AH	110	6.5	62	145	M8	182	140
	AI	110	6.5	52	165	M10	172	140
	AJ	130	6.5	52	165	M10	172	140
	AK	114.3	6.5	82	200	M10	202	185
AL	130	6.5	62	215	M12	182	185	
AM	180	6.5	62	215	M12	182	185	
260	AA	50	4	40	70	M4	185	102
	AB	60	4	40	75	M5	185	102
	AC	70	4	46	90	M5	191	102
	AD	80	4	46	100	M6	191	102
	AE	95	5	46	115	M8	191	115
	AF	95	5	56	130	M8	201	115
	AG	110	5	56	130	M8	201	115
	AH	110	6.5	66	145	M8	211	140
	AI	110	6.5	56	165	M10	201	140
	AJ	130	6.5	56	165	M10	201	140
	AK	114.3	6.5	86	200	M10	231	185
AL	130	6.5	66	215	M12	211	185	
AM	180	6.5	66	215	M12	211	185	
500	AA	80	4	46.5	100	M6	205.5	123
	AB	95	5	46.5	115	M8	205.5	123
	AC	95	5	56.5	130	M8	215.5	123
	AD	110	5	56.5	130	M8	215.5	123
	AE	110	6.5	66.5	145	M8	225.5	140
	AF	110	6.5	56.5	165	M10	215.5	140
	AG	130	6.5	56.5	165	M10	215.5	140
	AH	114.3	6.5	86.5	200	M10	245.5	185
	AI	130	6.5	66.5	215	M12	225.5	185
	AJ	180	6.5	66.5	215	M12	225.5	185
	AK	250	6.5	88.5	300	M14	247.5	260
800	AA	80	4	47	100	M6	229	123
	AB	95	5	47	115	M8	229	123
	AC	95	5	57	130	M8	239	123
	AD	110	5	57	130	M8	239	123
	AE	110	6.5	67	145	M8	249	140
	AF	110	6.5	57	165	M10	239	140
	AG	130	6.5	57	165	M10	239	140
	AH	114.3	6.5	87	200	M10	269	185
	AI	130	6.5	67	215	M12	249	185
	AJ	180	6.5	67	215	M12	249	185
	AK	250	6.5	89	300	M14	271	260

Servo Coupling

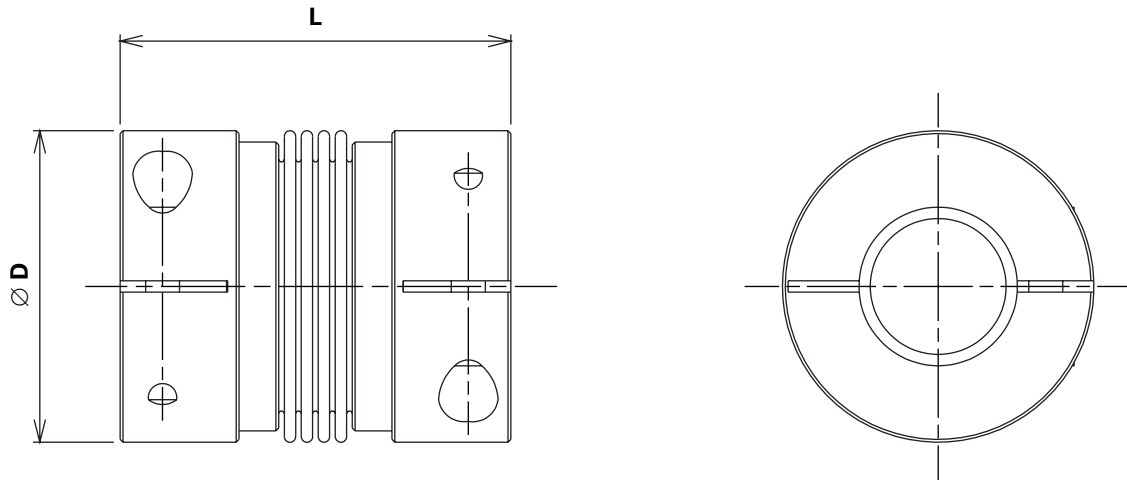

Coupling reference		060	080	150	300	500
Max. Ø servo shaft and SWG shaft	mm	Ø 35	Ø 42	Ø 42	Ø 60	Ø 62
Servo nominal torque	Nm	60	80	150	300	500
Servo peak torque	Nm	90	120	225	450	750
Ø D	mm	66	82	82	110	123
L	mm	79	92	92	109	114
Moment of inertia	10 ⁻³ kgm ²	0.20	0.60	0.65	2.68	9
Torsional stiffness	Nm/arcmin	21	23	41	46	85
Tightening torque of clamping screws	Nm	35	60	75	120	200

Specify the coupling reference and the motor shaft Ø when ordering.

Example : 150 Ø 42.

To calculate the total input inertia, add the coupling inertia to the gearbox inertia (page 7).

Servo Flange

Select the required flange on page 21.

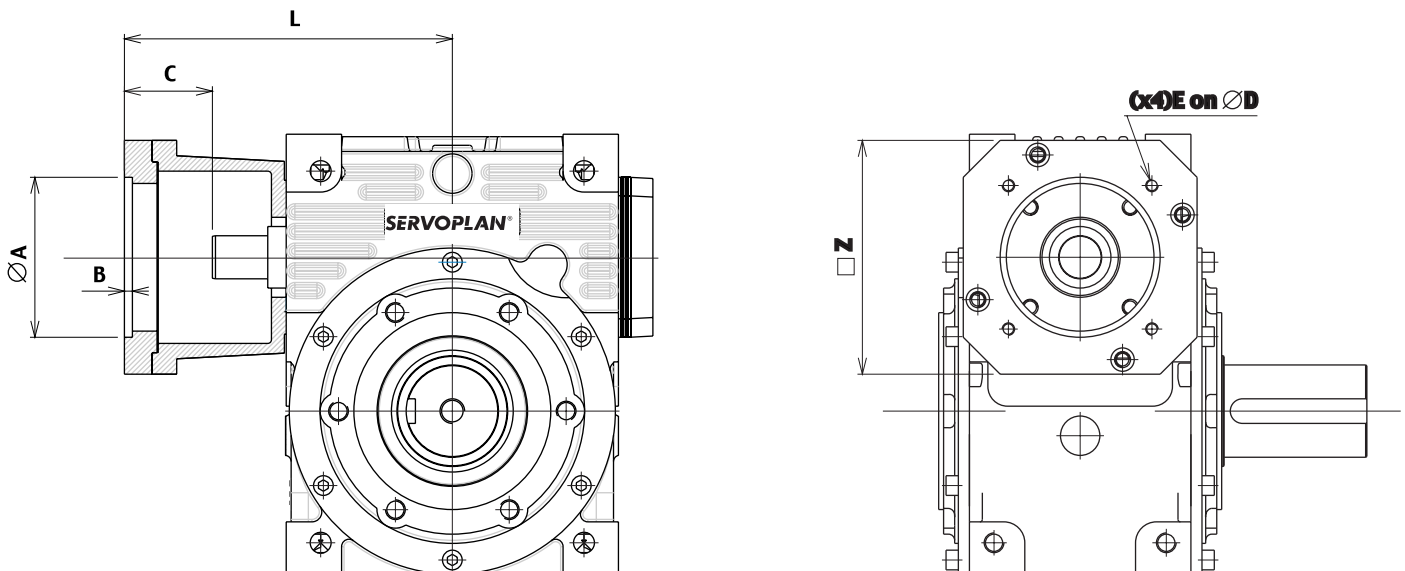

SWG	Reference	A	B	C min	D	E	L	Z
1500	AA	95	5	42	115	M8	247	190
	AB	95	5	52	130	M8	257	190
	AC	110	5	52	130	M8	257	190
	AD	110	6.5	62	145	M8	267	190
	AE	110	6.5	52	165	M10	257	190
	AF	130	6.5	52	165	M10	257	190
	AG	114.3	6.5	82	200	M10	287	190
	AH	130	6.5	62	215	M12	267	190
	AI	180	6.5	62	215	M12	267	190
	AJ	230	6.5	85	265	M12	290	260
	AK	250	6.5	85	300	M14	290	260
	AL	300	8.5	112	350	M16	317	360
2500	AA	130	6.5	52	165	M10	321	200
	AB	114.3	6.5	82	200	M10	351	200
	AC	130	6.5	62	215	M12	331	200
	AD	180	6.5	62	215	M12	331	200
	AE	230	6.5	85	265	M12	331	260
	AF	250	6.5	85	300	M14	354	260
	AG	300	8.5	112	350	M16	381	360
4800	AA	130	6.5	52	165	M10	365	200
	AB	114.3	6.5	82	200	M10	399	200
	AC	130	6.5	62	215	M12	379	200
	AD	180	6.5	62	215	M12	379	200
	AE	230	6.5	85	265	M12	402	260
	AF	250	6.5	85	300	M14	402	260
	AG	300	8.5	112	350	M16	429	360
	AH	350	10.5	142	400	M16	460	420

SWG - Gearbox Selection

Start/Stop Service S5

- Calculate acceleration torque on gearbox output :

$$C2acc = C1acc \times i^2 \times \eta \times F1 \times F2$$

F1 and **F2** : correction factors as per following chart.

GEARBOX RUNNING TIME DURING 1 FULL CYCLE					
	10 %	30 %	50 %	70 %	90 %
F1	0.7	0.85	1	1.11	1.2

NUMBER OF STARTS PER HOUR				
	1000 to 2000	2000 to 3000	3000 to 5000	5000 to 10000
F2	1 to 1.35	1.35 to 1.45	1.45 to 1.6	1.6 to 1.9

Intermediates values

To be interpolated

- Select the gearbox size in the column **Torque S5** :

$$\text{Torque S5} > C2acc$$

Continuous Service S1

- Calculate nominal torque on gearbox output

$$C2nom = C1nom \times i^2 \times \eta$$

- Select the gearbox size in the column **Torque S1** :

$$\text{Torque S1} > C2nom$$

LEGEND

- C1acc** (Nm) : motor acceleration torque
- C1nom** (Nm) : nominal motor torque
- C2acc** (Nm) : gearbox output acceleration torque
- C2nom** (Nm) : Gearbox output nominal torque
- E-stop** (Nm) : gearbox output emergency torque (2 seconds duration maximum, applied a maximum of 25000 times over the gearbox life)
- C1f** (Nm) : starting input friction torque (without any load on output)
- N1** : maximum input RPM to be achieved during a full cycle (S5 service) or input nominal RPM (S1 service)
- i** : exact gear ratio
- Et** (Nm/arcmin) : Torsional stiffness on output
- ig** (kgm²) : moment of inertia on input (to be added to coupling inertia, see page 10)
- η (%) : gearbox efficiency at considered input RPM
- Fr** (N) : permissible radial load on output shaft (applied at the middle of the shaft)
- Fa** (N) : permissible axial load on output shaft

Note: Indicated efficiency values are achieved after a 24 hours full load operation

Quotation Request:

Kindly fill out below questionnaire for speedy processing and send to:

Fax: ++49/(0)40 53540024

E-Mail: marzahl@marzahl.de

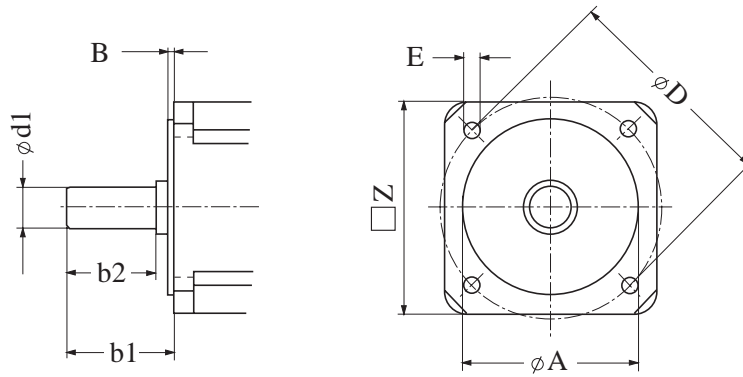

Motor data:

Motor manufacturer: _____
 Type: _____
 Motor shaft diameter d1 [mm]: _____
 Flange face distance b1 [mm]: _____
 Motor shaft length b2 [mm]: _____
 Centering diameter z1 [mm]: _____
 Fixing hole circle diameter e1 [mm]: _____
 Fixing hole diameter s1 [mm]: _____
 Flange square f [mm]: _____
 Motor nominal torque [Nm]: _____
 Motor maximum torque [Nm]: _____

Gearbox data:

Servoplan size: _____ **SWG-** _____
 Servoplan ratio [i]: _____
 Keyed output shaft (yes/no): _____
 Backlash specification (high Precision, Precision or Standard): _____
 Ordering number (see below): _____
 Basis of quotation (batch size): _____
 Projected annual volume: _____



Subject to technical change without notice. For studies, please request installation drawings; only the data contained therein is binding.

S W G 0 8 0 0 A 9 0 H - H 1 A E 0 3 0 - 1 9

Motor shaft \varnothing mm

Coupling reference (page 18/20)

Motor flange code (page 19/21)

Installation (page 9,11.13,15 and 17)

Output Options

N	Hollow shaft, no shrink disc
R	Robot flange
H	Hollow shaft including shrink disc
K	Hollow shaft with keyway
S	Single output shaft
D	Dual output shaft

Code Ratio	05	07	10	15	20	30	45	60	90
	5.2	7.25	10.25	14.5	19.5	30	45	60	90

Backlash

A	High precision 1 arcmin
B	Precision 3 arcmin
C	Standard 10 arcmin

Code Size	0030	0080	0120	0190	0260	0500	0800	1500	2500	4800
	30	80	120	190	260	500	800	1500	2500	4800

Example

S W G 0 8 0 0 A 9 0 H - H 1 A E 0 3 0 - 1 9

Marzahl Vertrieb GmbH
Ulzburger Straße 528
D-22844 Norderstedt
Telefon: +49(0)40-535-4000
Telefax: +49(0)40-535-40024
e-Mail: marzahl@marzahl.de
Internet: www.antriebstechniken.de