



ZF Maschinenantriebe GmbH  
Industrial Drives



**ZF-SERVOPLAN®**

*Planetary gearboxes*

*Economy Series*

for Servomotors

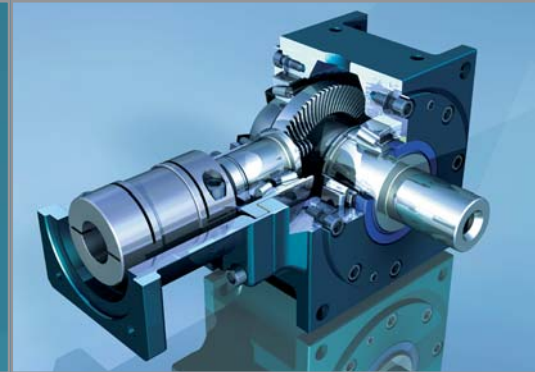
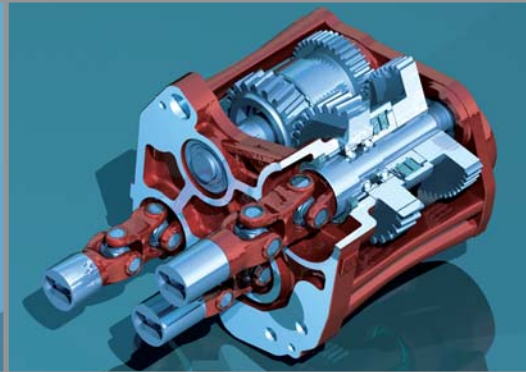
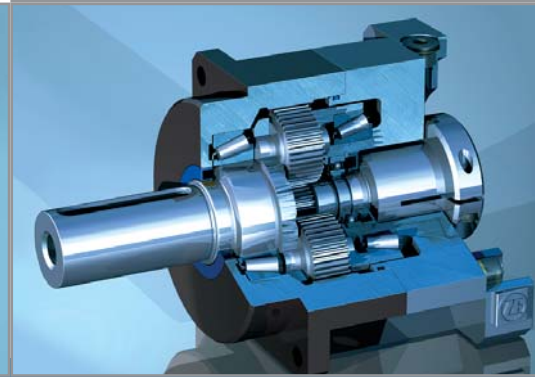
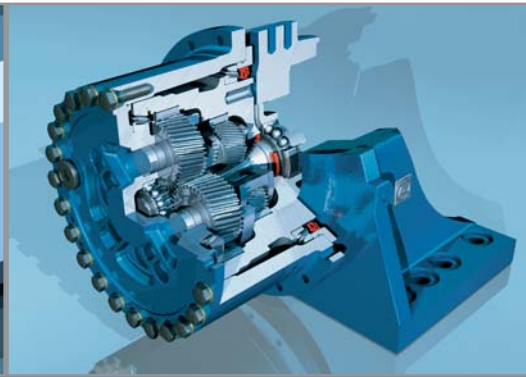
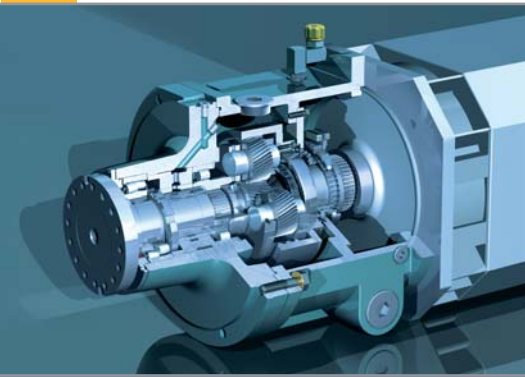
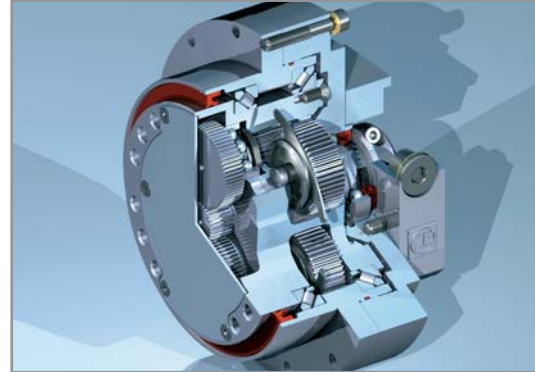

ZF-Duoplan 2K  
Two-speed Gearboxes

ZF-Ecolift  
Elevator Gearboxes

ZF-Servoplan CG  
Compact Gearbox

ZF-Tiratron  
Hysteresis Brakes

Customer specific  
Gearboxes

ZF-Servoplan PG  
Servogearboxes

ZF-Servoplan WT  
Right Angle gearboxes

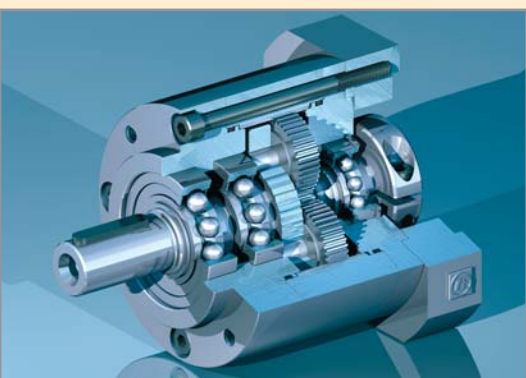

Z F - S e r v o p l a n P G E  
S e r v o g e a r b o x e s E c o n o m y

### *Precision in movement*

The ZF Maschinenantriebe GmbH is able to offer you a wide range of machine drives, brakes and clutches for applications in engineering as well as customer specific drive solutions.

Our development and production activities are focused on servo-assisted drives for automation engineering, two-speed drive gearboxes for machine tools as well as customer-specific drives, such as for printing machines, robot applications and elevator gearboxes.

Our innovative standard products range from low backlash servogearboxes (ZF-Servoplan), and robust two-speed gearboxes (ZF-Duoplan) to hysteresis clutches and brakes for non-contact web control (ZF-Tiratron).



The ZF-Servoplan planetary gearbox Economy series has been designed for direct mounting onto servomotors. The available wide range of sizes and the use of a modular system allows the application in almost any field of automation.

## Principle of Operation

The combination of servomotors with ZF-Servoplan planetary gearboxes constitutes a coaxial drive unit. The servomotor output shaft is connected to the sun gear of the gearbox by using a compression coupling. The sun gear drives three planetary gears inside the planetary carrier, which rotate inside the internal ring gear.

We feature a compact design with high power density thanks to equal force distribution among three planetary gears and robust performance due in part to hardened gears.

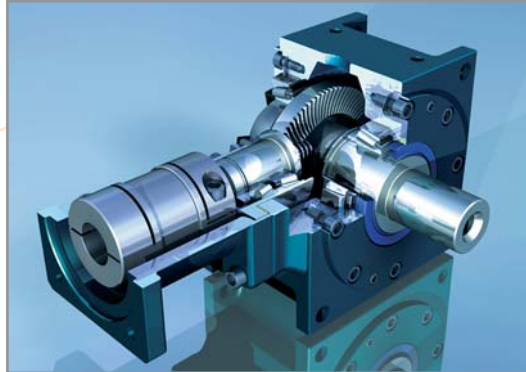

Also available from  
ZF Maschinenantriebe GmbH:  
Low backlash high precision  
right angle (ZF-Servoplan  
WT series) and planetary  
(ZF-Servoplan PG series)  
gearboxes.

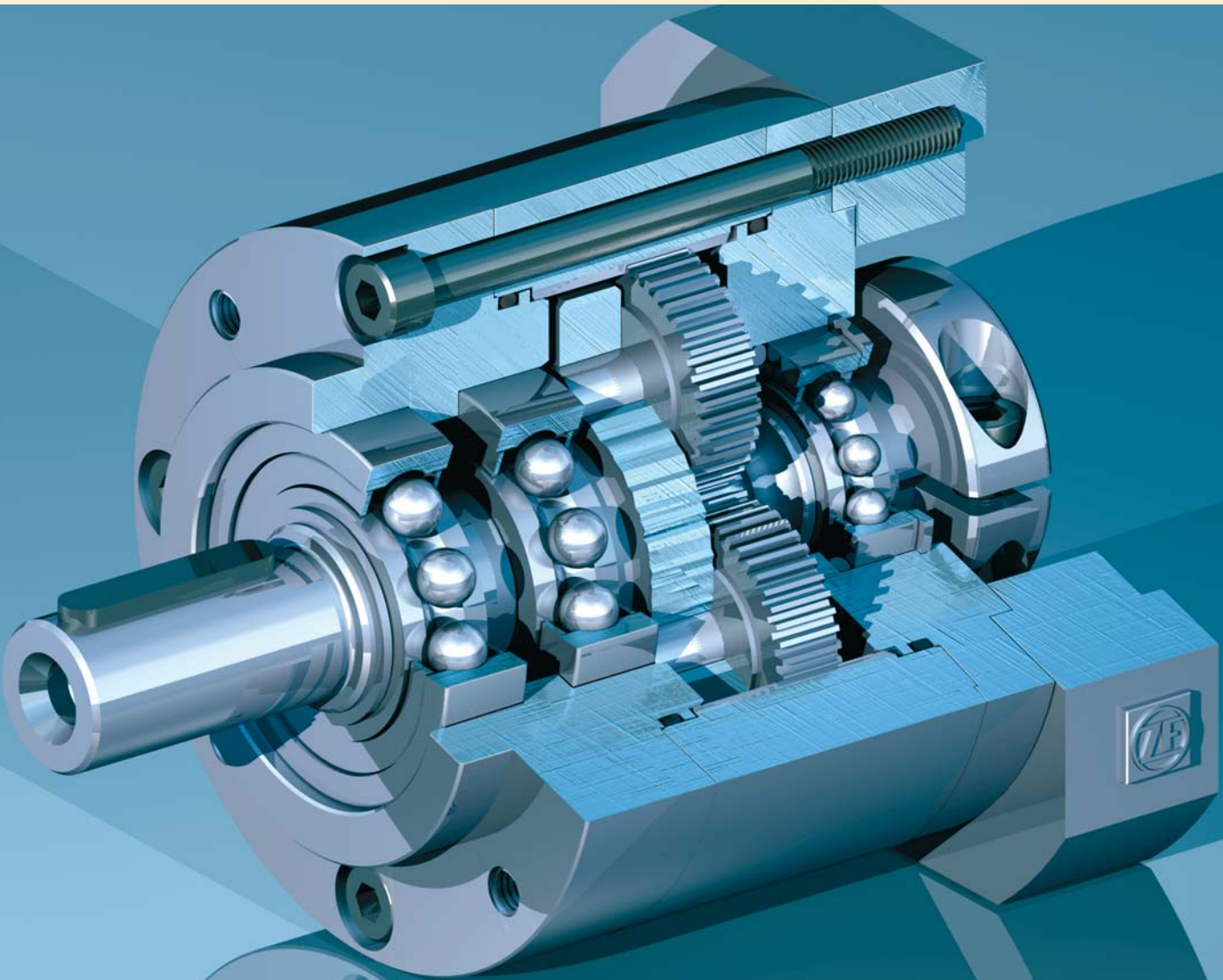

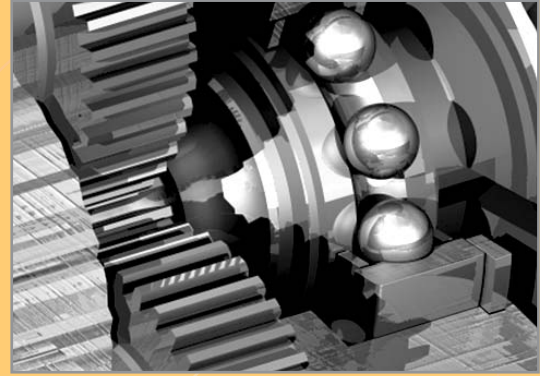

1. Easy motor mounting with modular adapter flange system.
2. Our input pilot ensures proper gearbox alignment to motor shaft, preventing shortened bearing life due to improper preloading.
3. High flexibility by using proven input coupling system.
4. Motor shaft / gearbox connection with compression coupling, ensuring a slip free and non-wearing power transmission.
5. Integrated axial length compensation system absorbing thermal growth of motor shaft.
6. High efficiency and low running noise thanks to high gearing quality, cageless needle bearings in planetary gears and high-grade lubricant.
7. High torsional rigidity and acceleration torques permitted due to robust design and optimized gearing geometry.
8. Six available gearbox sizes for output torques from 4 to 480 Nm.
9. Available ratios from  $i = 3$  to 1000.
10. Maintenance free with lifetime grease lubrication.
11. For use in any installation position.

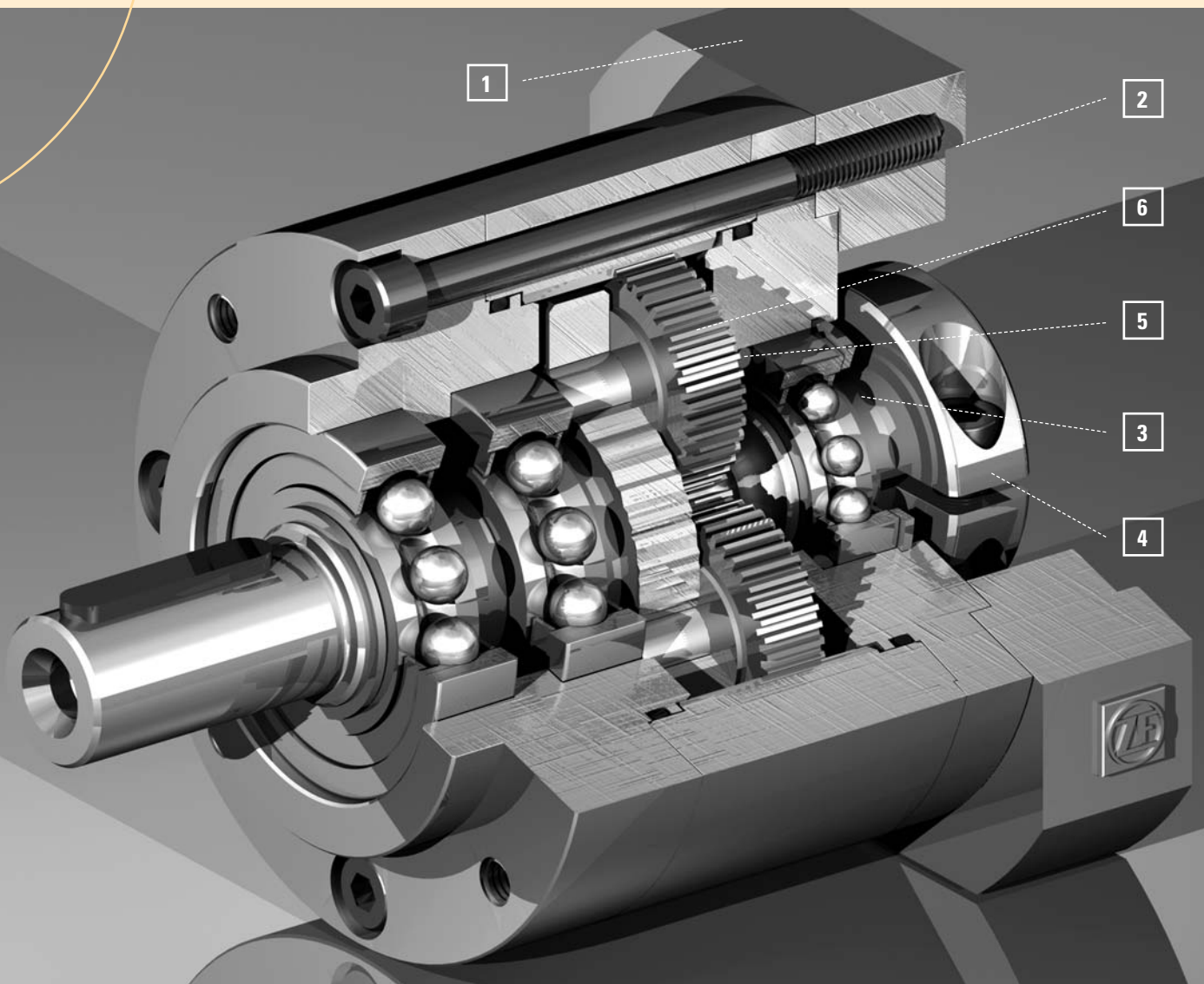
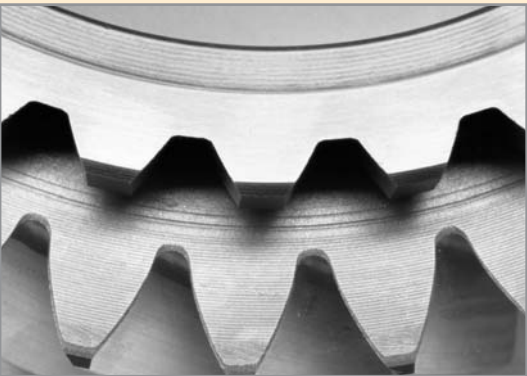

1

2

6

5

3

4

# Planetary Gearbox, one-stage

Size:

Technical Data:		Reduction Ratio $i$ :	PGE 12/1	PGE 25/1	PGE 50/1	PGE 100/1	PGE 200/1	PGE 500/1
Nominal output torque relating to $n_1 = 3000$ [rpm]	$T_{2N}$ [Nm]	<b>3</b> <b>4</b> <b>5</b> <b>7</b> <b>10 / 9*</b>	- 4 4.5 4.5 4*	13 14 16 15 14	35 45 45 43 35	85 90 110 90 80	160 250 270 270 160	290 440 460 460 290
Emergency stop torque <sup>1)</sup>	$T_{2Not}$ [Nm]	<b>3</b> <b>4</b> <b>5</b> <b>7</b> <b>10 / 9*</b>	- 12 13.5 13.5 12*	39 42 48 45 36	96 129 135 129 102	225 240 300 270 180	315 480 480 480 300	660 1 050 1 050 990 660
Max. acceleration torque <sup>2)</sup>	$T_{2B}$ [Nm]	<b>3</b> <b>4</b> <b>5</b> <b>7</b> <b>10 / 9*</b>	- 8 8 8 7*	25 28 32 28 25	70 88 90 86 70	160 180 210 160 160	290 375 405 405 290	460 620 645 645 460
Max. input speed	$n_{1Max}$ [rpm]	<b>3, 4, 5, 7</b> <b>10 / 9*</b>	6 000	6 000	5 000	5 000	3 600	3 600
Nominal input speed	$n_{1N}$ [rpm]	<b>3, 4, 5, 7</b> <b>10 / 9*</b>	3 000	3 000	3 000	3 000	2 600	2 000
Backlash	[arcmin]		20	12	10	10	10	10
Torsional rigidity	$C_t$ [Nm/arcmin]		0.4	1.6	4.8	10	34	80
Moments of inertia <sup>3)</sup>	$I_1$ [kg cm <sup>2</sup> ]	<b>3</b> <b>4</b> <b>5</b> <b>7</b> <b>10</b> <b>9*</b>	0.033 0.031 0.030 0.029	0.128 0.086 0.074 0.064 0.059	0.67 0.49 0.43 0.37 0.34	2.59 1.90 1.61 1.41 1.32	7.50 4.70 3.70 3.00 2.70	
Moments of inertia <sup>3)</sup>	$I_1$ [kg cm <sup>2</sup> ]	<b>3</b> <b>4</b> <b>5</b> <b>7</b> <b>10</b> <b>9*</b>	0.060 0.058 0.057 0.056	0.367 0.324 0.314 0.304 0.299	1.62 1.44 1.36 1.30 1.27	3.66 2.97 2.68 2.48 2.39	10.60 7.80 6.80 6.10 5.80	20.20 12.80 10.10 8.00 6.80
Max. axial force	$F_A$ [N]		230	615	1 135	1 980	3 560	5 700
Max. radial force <sup>4)</sup>	$F_R$ [N]		155	530	925	1 630	3 120	4 500
Lifetime	$L_h$ [h]		20 000	20 000	20 000	20 000	20 000	20 000
Efficiency	$\eta$		96%	97%	96%	96%	96%	96%
Weight ca.	$m$ [kg]		0.4	1.3	2.6	6	12.5	23
Operating noise at $n_{an} = 3000$ [rpm]	$L_p$ [dB(A)]		≤ 70	≤ 70	≤ 70	≤ 70	≤ 70	≤ 70
Lubrication:	Lifetime grease lubrication, closed system							
Surface protection	Steel housing, galvanically treated. Aluminum flanges.							
Installation position	Any, including variable orientation.							
Operating temperature	- 10° C to + 90 °C							
Direction of rotation	same as input							
Degree of protection	IP 64							

1) Max. 1000 times during gearbox lifetime.

2) At a maximum of 1000 cycles per hour.  
Percentage of the overall running time less than 5 % and duration of the impulse under 0.3 sec.

3) dependent on motor shaft diameter (see D6).

4) Resultant force middle of output shaft at output speed 100 rpm.

\* for PGE 12/1  $i = 9$  all others  $i = 10$

**Printed in bold letters: Shorter delivery time.**

Size:

Dimensions [mm]:

		PGE 12/1	PGE 25/1	PGE 50/1	PGE 100/1	PGE 200/1	PGE 500/1
DR		DM4	DM5	DM6	DM10	DM16	DM20
t1		10	12,5	16	22	36	42
D1 (h7)		25	40	55	80	110	140
D2		12	17	25	30	50	65
D3 (k6)		10	14	20	25	40	55
D4		M4	M5	M6	M8	M10	M12
D5		33	52	70	100	130	165
D6*(F6)	min.	3	6	9	14	19	24
	max.	11	14	19	24	32	32
D7*,D8*,D9*		Adaptations available for all common servomotors, dimensions are variable					
D10		40	65	85	120	155	190
L1		95	127,5	161	196	262	297
L2		23	30	40	50	80	100
L3		6	9	9	11	15	17
L5		27	23	28	31	39	39
L6	min.	14	19	24	27	30	30
	max.	26	30,5	41	51	63	63
L7*		3	4	4,5	5,5	6,5	6,5
L12		1	1	1	1	1	1
L13*	min.	40	65	85	120	155	190
L14		18	25	32	40	70	80
L15		2	2,5	3	3	5	10
L16		3	5	6	8	12	16
L17		11,2	16	22,5	28	43	59
L22*		3,5	5	5,5	6,5	8,5	8,5

\*Dimensions depending on motor.

Please use page 17 for inquiries and orders.

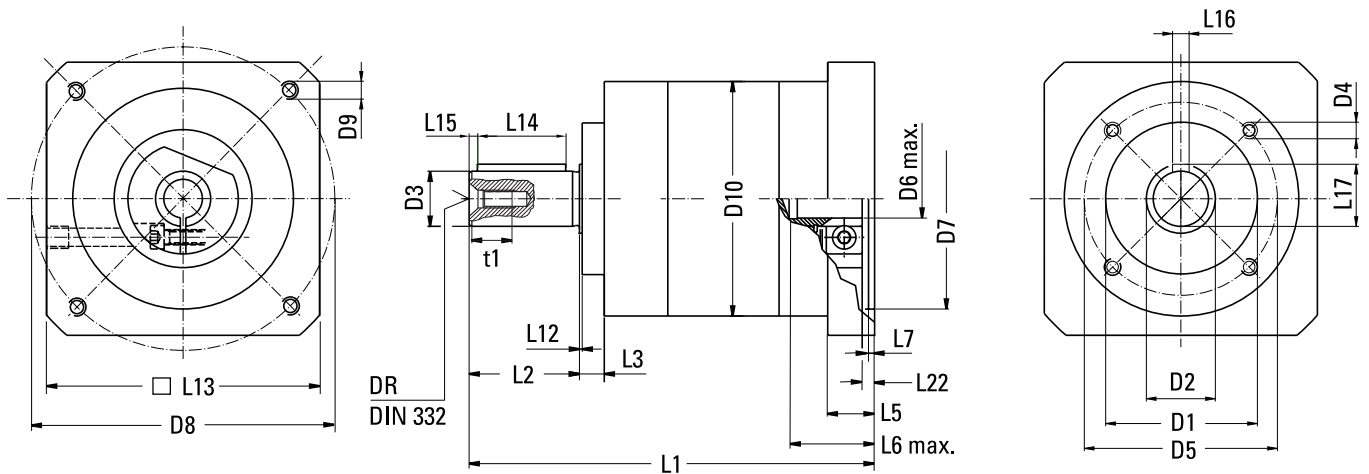

# Planetary Gearbox, two-stage

Size:

Technical Data:		Reduction Ratio i:	Size:					
			PGE 12/2	PGE 25/2	PGE 50/2	PGE 100/2	PGE 200/2	PGE 500/2
Nominal output torque relating to $n_1 = 3000$ [rpm]	$T_{2N}$ [Nm]	<b>16</b> 20 25 28 35 40 / 49* 50 70 100	5 5 5 5 5 5*	19 19 21 21 21 21 21 17 16	55 55 58 55 58 55 58 50 35	100 100 110 100 110 100 110 95 85	270 270 290 270 290 270 290 290 170	460 460 480 460 480 460 480 480 310
Emergency stop torque <sup>1)</sup>	$T_{2Not}$ [Nm]	<b>16</b> 20 25 28 35 40 / 49* 50 70 100	15 15 15 15 15 15*	57 57 63 63 63 63 63 51 42	165 165 174 165 174 165 174 150 105	300 300 330 300 330 300 330 285 186	510 510 510 510 540 510 600 540 390	1 140 1 140 1 140 1 140 1 200 1 140 1 140 990 780
Max. acceleration torque <sup>2)</sup>	$T_{2B}$ [Nm]	<b>16</b> 20 25 28 35 40 / 49* 50 70 100	10 10 10 10 10 10*	34 34 40 40 40 40 40 32 29	98 98 105 98 105 98 105 90 70	180 180 210 180 210 180 210 175 160	405 405 435 405 435 405 435 435 310	645 645 670 645 670 645 670 670 500
Max. input speed	$n_{1Max}$ [rpm]	<b>12, 15, 16, 20, 25, 28, 35, 40 / 49*, 50, 70, 100</b>	6 000	6 000	5 000	5 000	3 600	3 600
Nominal input speed	$n_{1N}$ [rpm]	<b>12, 15, 16, 20, 25, 28, 35, 40 / 49*, 50, 70, 100</b>	3 000	3 000	3 000	3 000	3 000	2 600
Backlash			25	15	15	15	15	15
Torsional rigidity	$C_t$ [Nm/arcmin]		0.5	2	6	13	37	85
Moments of inertia <sup>3)</sup>	$I_1$ [kg cm <sup>2</sup> ]	<b>16</b> 20 25 28 35 40 49* 50 70 100	0.033 0.031 0.031 0.031 0.030 0.030 0.030	0.083 0.072 0.072 0.063 0.063 0.059 0.059	0.48 0.42 0.42 0.37 0.37 0.34 0.34	1.89 1.61 1.60 1.41 1.40 1.33 1.32	3.90 3.30 3.20 3.00 2.90 2.70 2.70	$D60 \leq 9$ $D60 \leq 11$ $D60 \leq 14$ $D60 \leq 14$ $D60 \leq 19$ $D60 \leq 24$
Moments of inertia <sup>3)</sup>	$I_1$ [kg cm <sup>2</sup> ]	<b>16</b> 20 25 28 35 40 49* 50 70 100	0.060 0.058 0.058 0.058 0.057 0.057	0.321 0.312 0.311 0.303 0.303 0.299	1.42 1.35 1.35 1.29 1.29 1.26	2.96 2.68 2.67 2.48 2.47 2.40	7.00 6.40 6.30 6.10 6.00 5.80	$D60 \leq 11$ $D60 \leq 14$ $D60 \leq 19$ $D60 \leq 24$ $D60 \leq 32$ $D60 \leq 32$
Max. axial force	$F_A$ [N]		230	615	1 135	1 980	3 560	5 700
Max. radial force <sup>4)</sup>	$F_R$ [N]		155	530	925	1 630	3 120	4 500
Lifetime	$L_h$ [h]		20 000	20 000	20 000	20 000	20 000	20 000
Efficiency	$\eta$		94%	94%	94%	94%	94%	94%
Weight ca.	$m$ [kg]		0.5	1.7	3.5	8.6	17	31
Operating noise at $n_{an} = 3000$ [rpm]	$L_p$ [dB(A)]		≤ 70	≤ 70	≤ 70	≤ 70	≤ 70	≤ 70
Lubrication:		Lifetime grease lubrication, closed system						
Surface protection		Steel housing, galvanically treated. Aluminum flanges.						
Installation position		Any, including variable orientation.						
Operating temperature		- 10° C to + 90 °C						
Direction of rotation		same as input						
Degree of protection		IP 64						

1) Max. 1000 times during gearbox lifetime.

2) At a maximum of 1000 cycles per hour.

Percentage of the overall running time less than 5 % and duration of the impulse under 0.3 sec.

3) dependent on motor shaft diameter (see D6).

4) Resultant force middle of output shaft at output speed 100 rpm.

\* for PGE 12/1 i = 49 all others i = 40

**Printed in bold letters: Shorter delivery time.**

Size:

Dimensions [mm]:

		PGE 12/2	PGE 25/2	PGE 50/2	PGE 100/2	PGE 200/2	PGE 500/2
DR		DM4	DM5	DM6	DM10	DM16	DM20
t1		10	12.5	16	22	36	42
D1 (h7)		25	40	55	80	110	140
D2		12	17	25	30	50	65
D3 (k6)		10	14	20	25	40	55
D4		M4	M5	M6	M8	M10	M12
D5		33	52	70	100	130	165
D6*(F6)	min.	3	6	9	14	19	24
	max.	11	14	19	24	32	32
D7*,D8*,D9*	Adaptations available for all common servomotors, dimensions are variable						
D10		40	65	85	120	155	190
L1		111	151.5	192	232	306	351
L2		23	30	40	50	80	100
L3		6	9	9	11	15	17
L5		27	23	28	30	39	39
L6	min.	14	18	22	28	30	30
	max.	26	30	40	50	60	60
L7*		3	4	4.5	5.5	6.5	6.5
L12		1	1	1	1	1	1
L13*	min.	40	65	85	120	155	190
L14		18	25	32	40	70	80
L15		2.5	2.5	4	5	5	10
L16		3	5	6	8	12	16
L17		11.2	16	22.5	28	43	59
L22*		3.5	4.5	5.5	6.5	8.5	8.5

\*Dimensions depending on motor.

Please use page 17 for inquiries and orders.

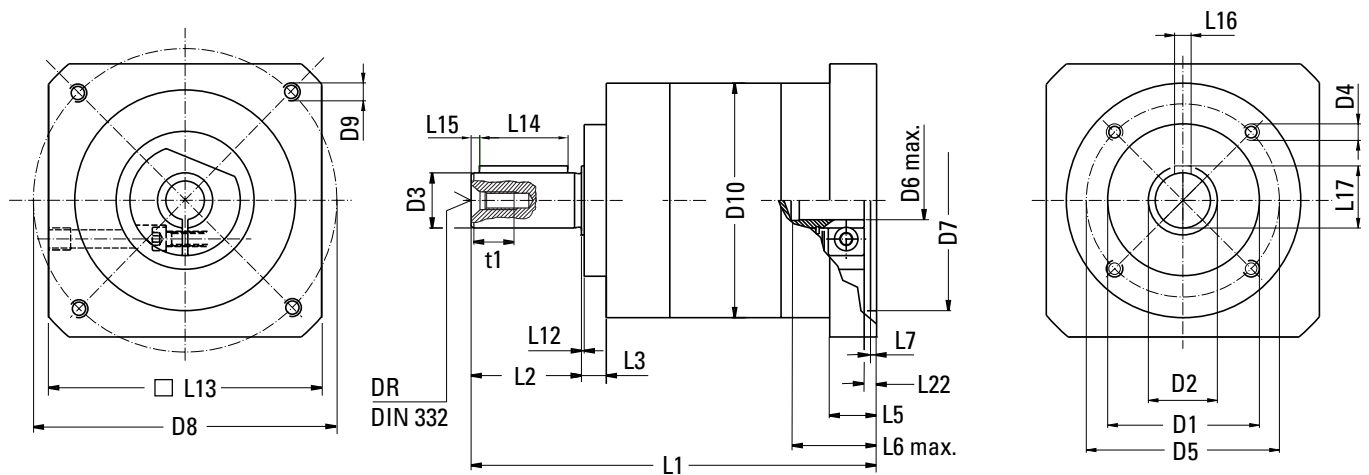

# Planetary Gearbox, three-stage

Size:

Technical Data:		Reduction Ratio $i$ :	PGE 12/3	PGE 25/3	PGE 50/3	PGE 100/3	PGE 200/3	PGE 500/3
Nominal output torque relating to $n_1 = 3000$ [rpm]	$T_{2N}$ [Nm]	64, 80, 100 120 140 160 175 200 245 250 343 350, 500 700 729 1 000	5 5 5 5 5 5	21 21 21 21 21 19	55 55 58 58 58 50	100 100 100 110 110 95	170 270 270 290 290 290	310 460 460 480 480 480
Emergency stop torque <sup>1)</sup>	$T_{2Not}$ [Nm]	64, 80, 100 120 140 160 175 200 245 250 343 350, 500 700 729 1 000	15 15 15 15 15 15	63 63 63 63 63 57	165 165 174 174 174 150	300 300 300 330 330 285	450 540 600 600 600 540	870 1 140 1 140 1 140 1 140 1 050
Max. acceleration torque <sup>2)</sup>	$T_{2B}$ [Nm]	64, 80, 100 120 140 160 175 200 245 250 343 350, 500 700 729 1 000	10 10 10 10 10 10	40 40 40 40 40 38	100 100 105 110 110 95	180 200 200 210 210 190	310 405 405 435 435 435	500 645 645 670 670 670
Max. input speed	$n_{1Max}$ [rpm]	120 160, 200 250, 350, 500 700 1 000	6 000	6 000	5 000	5 000	3 600	3 600
Nominal input speed	$n_{1N}$ [rpm]	120 160, 200 250, 350, 500 700 1 000		3 000	3 000	3 000	3 000	2 600
Backlash	[arcmin]			30	20	20	20	20
Torsional rigidity	$C_t$ [Nm/arcmin]		0.6	2.1	5.5	12	38	94
Moments of inertia <sup>3)</sup>	$I_1$ [kg cm <sup>2</sup> ]	64, 80, 100, 140, 175, 245 343, 729 120 160 200 250 350 500 700 1000	0.030 0.030 0.030	$D6 \leq 9$ 0.059 0.059 0.059 0.059 0.059 0.059 0.059	$D6 \leq 11$ 0.34 0.34 0.34 0.34 0.34 0.34 0.34	$D6 \leq 14$ 1.32 1.32 1.32 1.32 1.32 1.32 1.32	$D6 \leq 19$ 2.70 2.70 2.70 2.70 2.70 2.70 2.70	$D6 \leq 24$ 3.00 3.00 3.00 3.00 3.00 3.00 3.00
Max. axial force	$F_A$ [N]		230	615	1 135	1 980	3 560	5 700
Max. radial force <sup>4)</sup>	$F_R$ [N]		155	530	925	1 630	3 120	4 500
Lifetime	$L_h$ [h]		20 000	20 000	20 000	20 000	20 000	20 000
Efficiency	$\eta$		90%	90%	90%	90%	90%	90%
Weight ca.	$m$ [kg]		0.6	2.2	4.4	10.5	20	36
Operating noise at $n_{an} = 3000$ [rpm]	$L_p$ [dB(A)]		$\leq 70$	$\leq 70$	$\leq 70$	$\leq 70$	$\leq 70$	$\leq 70$
Lubrication:	Lifetime grease lubrication, closed system							
Surface protection	Steel housing, galvanically treated. Aluminum flanges.							
Installation position	Any, including variable orientation.							
Operating temperature	- 10° C to + 90° C							
Direction of rotation	same as input							
Degree of protection	IP 64							

1) Max. 1000 times during gearbox lifetime.

2) At a maximum of 1000 cycles per hour.  
Percentage of the overall running time less than 5 % and duration of the impulse under 0.3 sec.

3) dependent on motor shaft diameter (see D6).

4) Resultant force middle of output shaft at output speed 100 rpm.

Size:

Dimensions [m m]:

		PGE 12/3	PGE 25/3	PGE 50/3	PGE 100/3	PGE 200/3	PGE 500/3
DR		DM4	DM5	DM6	DM10	DM16	DM20
t1		10	12.5	16	22	36	42
D1 (h7)		25	40	55	80	110	140
D2		12	17	25	30	50	65
D3 (k6)		10	14	20	25	40	55
D4		M4	M5	M6	M8	M10	M12
D5		33	52	70	100	130	165
D6*(F6)	min.	3	6	9	14	19	22
	max.	9	11	14	19	24	24
D7*,D8*,D9*	Adaptations available for all common servomotors, dimensions are variable						
D10		40	65	85	120	155	190
L1		122	171	213	256	322	376
L2		23	30	40	50	80	100
L3		6	9	9	11	15	17
L5		22	20	26	31	37	37
L6	min.	11	14	18	24	26	26
	max.	22	27	30	41	52	52
L7*		3	4	4.5	5.5	6.5	6.5
L12		1	1	1	1	1	1
L13*	min.	40	65	85	120	155	190
L14		18	25	32	40	70	80
L15		2	2.5	3	3	5	10
L16		3	5	6	8	12	16
L17		11.2	16	22.5	28	43	59
L22*		3.5	4.5	5.5	6.5	8.5	8.5

\*Dimensions depending on motor.

Please use page 17 for inquiries and orders.

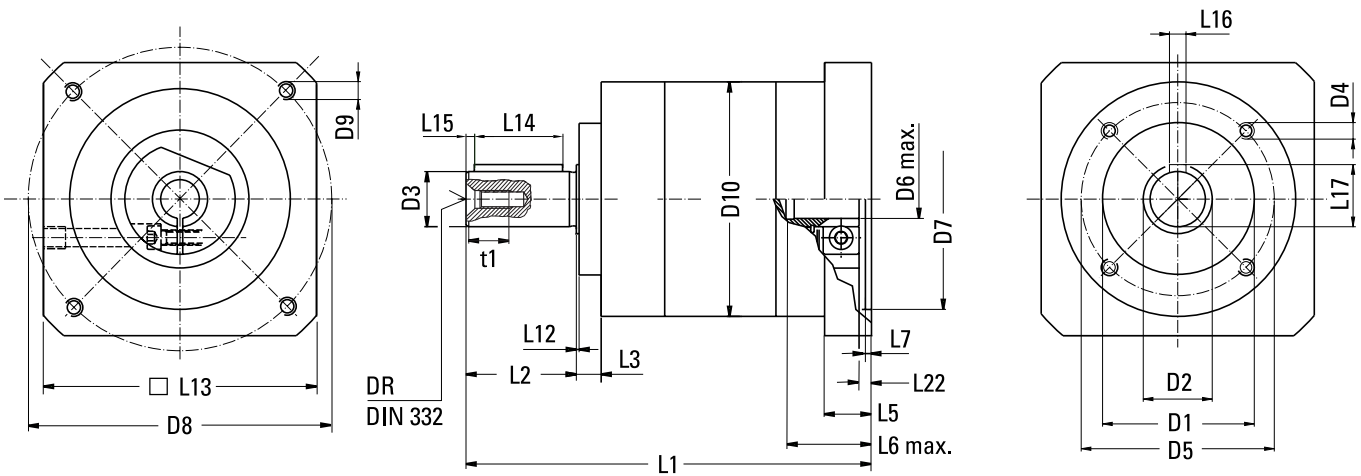

# Permitted shaft loads

The permissible axial or radial shaft loads are based on nominal bearing lifetime, see diagrams below.

The application point of the resultant forces is at middle of output shaft. The values for  $F_R$  do not take any axial loads into account. For cases with combined axial and radial forces, the force values are reduced.

If the radial force  $F_R$  acts on the output shaft outside its centre, the permissible force values are reduced ( $x > \frac{L_2}{2}$ ) or increased ( $x < \frac{L_2}{2}$ ), respectively.

## Degree of protection

The degree of protection is defined by the designation IP (International Protection corresponding EN 60529) and two digits. For our gearboxes the designation is IP 64.

The first digit designates the degree of protection against contact (screen protection) and penetration of foreign bodies.

In this instance, the first digit 6 means:

- protection against dust infiltration (dust-tight)
- complete screen protection.

The second digit designates the degree of protection against water.

In this instance, the digit 4 means:

- protection against spray water from all directions.

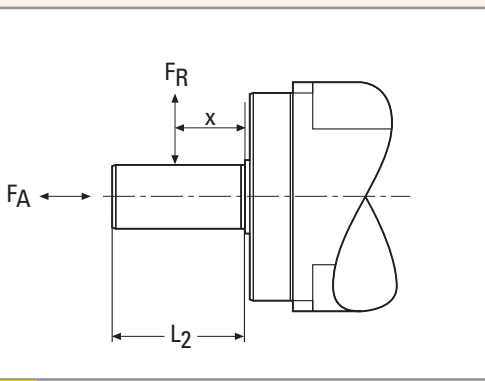

Force (load) application points on gearbox output shaft

$F_A$  = permitted axial force  
 $F_R$  = permitted radial force  
 $x$  = distance

## Bearing Lifetime in Relation to Output Speed and Radial Force

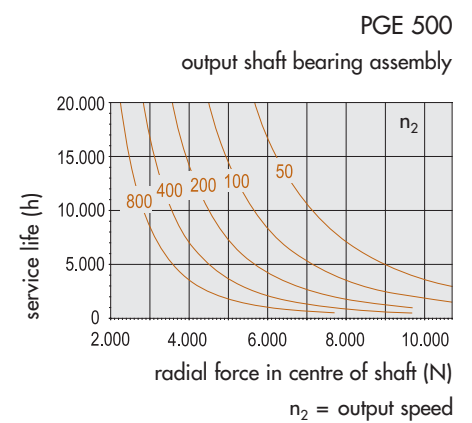
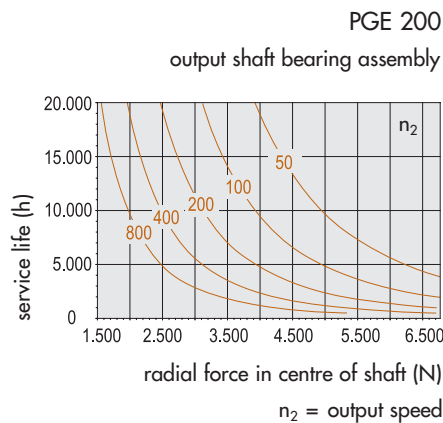
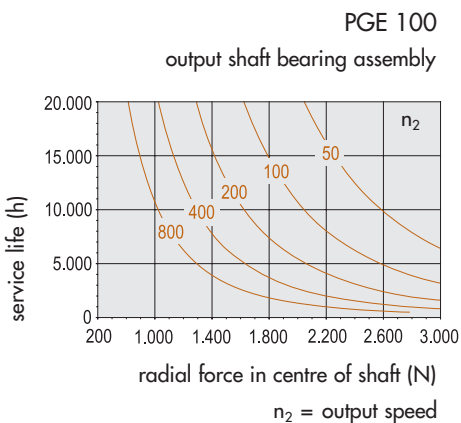
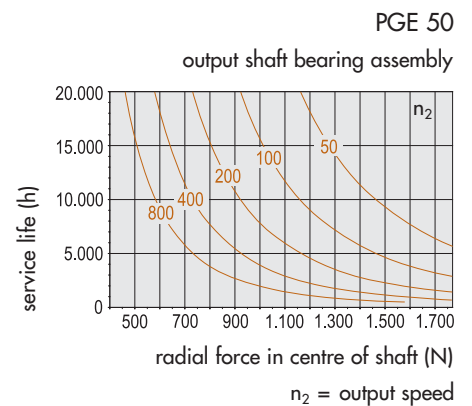
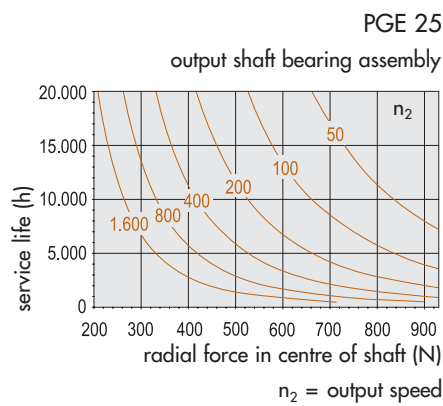
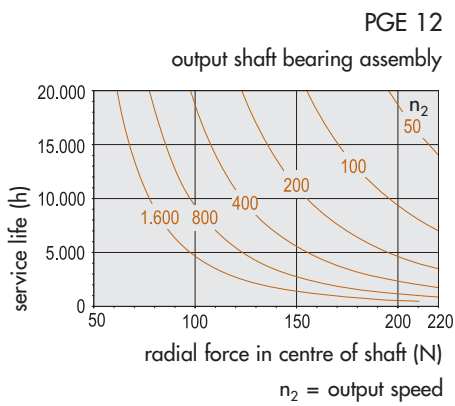

# Gearbox Output Shaft

The gearbox output shaft is available in the following designs:

**Standard:**

Output shaft with key as per DIN 6885 sheet 1 (08.68 issue) for keyed shaft-hub connections. This type of connection is suitable for constant direction, where applications, requirements are not as stringent. This connection type requires additional axial fixing of the hub. A centering bore with thread is provided on the face end of the gearbox output shaft for this purpose (as per DIN 332, sheet 2).

**Options:** fitted with a half key.

Plain output shaft on special request.

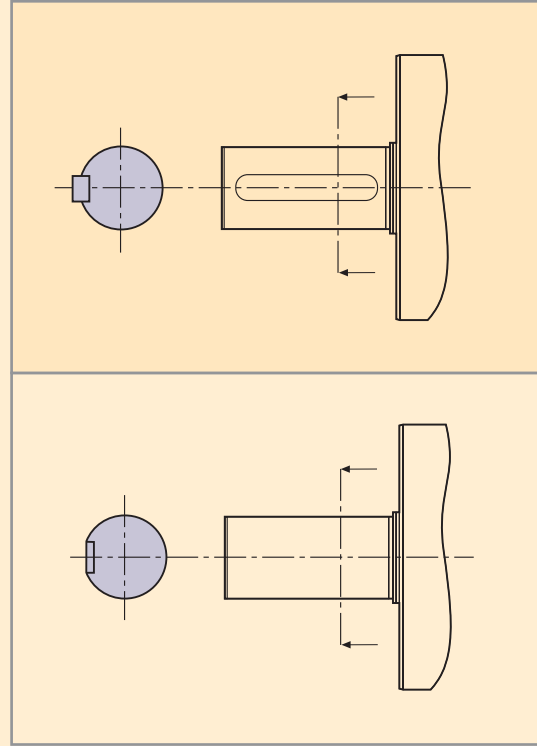

Size:

		PGE 12/1 12/2 12/3	PGE 25/1 25/2 25/3	PGE 50/1 50/2 50/3	PGE 100/1 100/2 100/3	PGE 200/1 200/2 200/3	PGE 500/1 500/2 500/3
Thread	DIN 332	M4	M5	M6	M10	M16	M20
$T_A$	[Nm]	3.4	5.5	9.5	46	190	380
$F_V$	[kN]	4.1	6.5	9.5	27	74	110

$T_A$  = Tightening torque  
 $F_V$  = Pretensioning Force

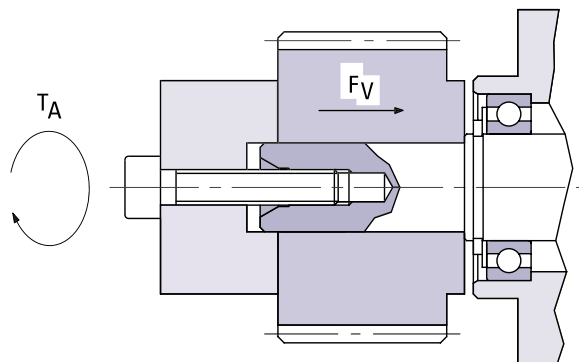

# Configuration and Selection

## Gearbox selection

The quickest and most reliable method, to determine the appropriate gearbox size for a specific application, is a comparison of motor peak torque with gearbox datas.

Applications are differentiated based on norm EN 60034-1 as to continuous duty (S1) or intermittent cyclic duty (S4/S5). For intermittent cyclic duties the maximum motor acceleration torque is relevant, whereas for continuous duties motor nominal torque is used. In case the motor peak torque

exceeds the permitted gearbox values, a calculation based on the actual application specific torques is required.

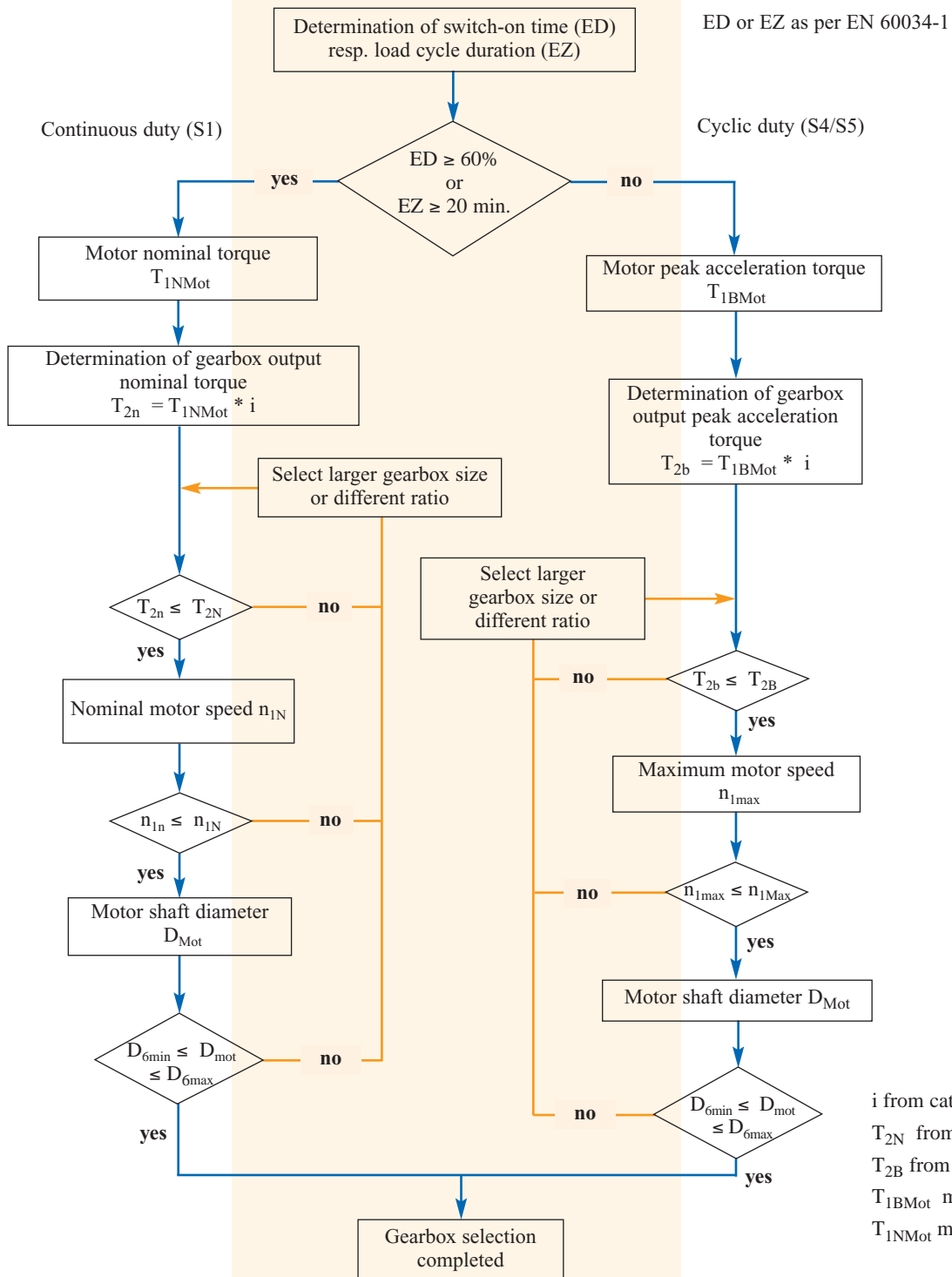

1) For nos. of cycles ≤ 1000 cycles per hour, and percentage of total running time ≤ 5% and duration of impulse less than 0.3 sec.

# Quotation Request:

Kindly fill out below questionnaire for speedy processing and send to:

Fax: ++49/(0)7541/77-3470 or

E-Mail: industrial-drives@zf.com

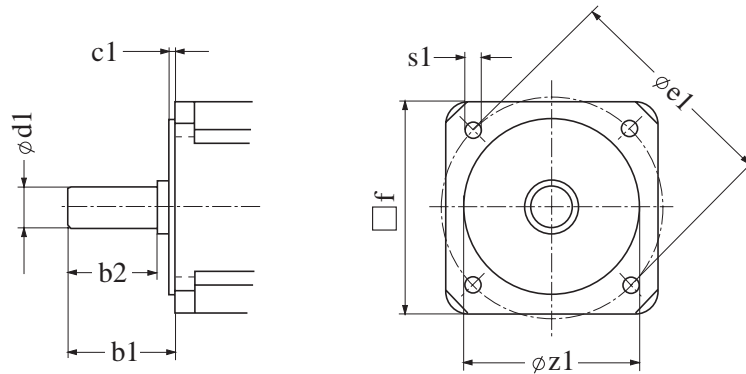

## Motor data:

Motor manufacturer: \_\_\_\_\_

Type: \_\_\_\_\_

Motor shaft diameter d1 [mm]: \_\_\_\_\_

Flange face distance b1 [mm]: \_\_\_\_\_

Motor shaft length b2 [mm]: \_\_\_\_\_

Pilot diameter z1 [mm]: \_\_\_\_\_

Pcd diameter e1 [mm]: \_\_\_\_\_

Fixing hole diameter s1 [mm]: \_\_\_\_\_

Flange square  f [mm] \_\_\_\_\_

Motor nominal torque [Nm]: \_\_\_\_\_

Motor maximum torque [Nm]: \_\_\_\_\_

## Gearbox data:

ZF-Servoplan size: \_\_\_\_\_

PGE- \_\_\_\_\_

ZF-Servoplan ratio [i]: \_\_\_\_\_

Keyed output shaft (yes/no): \_\_\_\_\_

Ordering type code (see page 17): \_\_\_\_\_

Basis of quotation (batch size): \_\_\_\_\_

Projected annual volume: \_\_\_\_\_

Subject to technical change without notice. For studies, please request installation drawings; only the data contained therein is binding. Please refer also to our homepage: [http:// industrial-drives.zf.com](http://industrial-drives.zf.com)

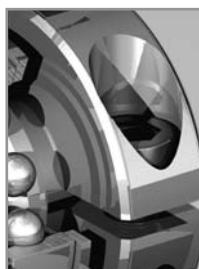
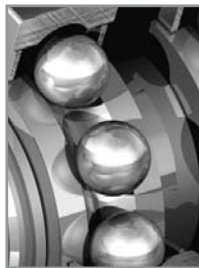

# Ordering Type Code

PGE - -

1 2 3 - 4 5 6 7 8 9 - 10 11 12

Size	Size Code
PGE 12/1, PGE 12/2, PGE 12/3	001
PGE 25/1, PGE 25/2, PGE 25/3	002
PGE 50/1, PGE 50/2, PGE 50/3	005
PGE 100/1, PGE 100/2, PGE 100/3	010
PGE 200/1, PGE 200/2, PGE 200/3	020
PGE 500/1, PGE 500/2, PGE 500/3	050

Size	D6 [mm]	Motor Shaft Code	
PGE 12	3	A	
	4	B	
	5	C	
	6	D	
	7	E	
	8	F	
	9	G	
	10	H	
	11	I	
	PGE 25	6	A
		7	B
8		C	
9		D	
10		E	
11		F	
12		G	
14		H	
PGE 50	9	A	
	10	B	
	11	C	
	12	D	
	14	E	
	15	F	
	16	G	
PGE 100	14	A	
	15	B	
	16	C	
	19	D	
	22	E	
PGE 200	19	A	
	22	B	
	24	C	
	28	D	
	32	E	
PGE 500	22	A	
	24	B	
	28	C	
	32	D	

Size	D7 [mm]	D8 [mm]	D9 [mm]	L6 min [mm]	L6 max [mm]	L7 [mm]	L22 [mm]	Flange-Code	
PGE 12	25.0	32.0	M3	15.0	27.0	3.0	4.5	AA	
	25.0	63.0	M5	14.0	26.0	3.0	3.5	AB	
	30.0	46.0	M4	14.0	26.0	3.0	3.5	AC	
	35.0	65.5	M5	14.0	26.0	3.0	3.5	AD	
	30.0	46.0	M5	14.0	26.0	3.0	3.5	AE	
	30.0	46.0	M4	14.0	26.0	3.0	3.5	AF	
	35.0	65.5	M5	14.0	26.0	3.0	3.5	AG	
	30.0	45.0	M3	15.0	27.0	3.5	4.5	AH	
	50.0	70.0	M4	18.0	30.0	3.5	7.5	AI	
	22.0	43.8	∅ 3.5	14.0	26.0	2.5	3.5	AJ	
	22.0	48.0	M3	14.0	26.0	3.0	3.5	AK	
	PGE 25	30.0	45.0	M3	19.0	30.5	4.0	5.0	AA
		30.0	46.0	M4	19.0	30.5	4.0	5.0	AB
36.0		70.7	M4	19.0	30.5	4.0	5.0	AC	
40.0		63.0	M4	19.0	30.5	4.0	5.0	AD	
40.0		63.0	M5	19.0	30.5	4.0	5.0	AE	
40.0		70.0	M4	19.0	30.5	4.0	5.0	AF	
50.0		60.0	M4	19.0	30.5	4.0	5.0	AG	
50.0		65.0	M5	19.0	30.5	4.0	5.0	AH	
50.0		70.0	M4	19.0	30.5	4.0	5.0	AI	
50.0		70.0	M5	19.0	30.5	4.0	5.0	AJ	
50.0		80.0	M5	19.0	30.5	4.0	5.0	AK	
50.0		95.0	M6	19.0	30.5	4.0	5.0	AL	
50.0		100.0	M6	19.0	30.5	4.0	5.0	AM	
60.0		75.0	M5	19.0	30.5	4.0	5.0	AN	
60.0		90.0	M5	19.0	30.5	4.0	5.0	AO	
70.0		90.0	M5	21.0	32.5	4.0	7.0	AP	
70.0		90.0	M5	23.0	34.5	5.5	9.0	AQ	
70.0	90.0	M6	19.0	30.5	4.0	5.0	AR		
73.1	98.5	M5	19.0	30.5	4.0	5.0	AS		
80.0	100.0	M6	19.0	30.5	4.0	5.0	AT		
22.0	48.0	M3	19.0	30.5	4.0	5.0	AU		
45.0	65.5	M5	19.0	30.5	4.0	5.0	AV		
73.1	99.0	M6	22.0	33.5	4.0	8.0	AW		
80.0	100.0	M6	29.0	40.5	7.0	15.0	AX		
PGE 50	50.0	60.0	M4	24.0	41.0	4.5	5.5	AA	
	50.0	65.0	M5	24.0	41.0	4.5	5.5	AB	
	50.0	70.0	M4	24.0	41.0	4.5	5.5	AC	
	50.0	70.0	M5	24.0	41.0	4.5	5.5	AD	
	50.0	80.0	M5	24.0	41.0	4.5	5.5	AE	
	50.0	95.0	M6	24.0	41.0	4.5	5.5	AF	
	50.0	100.0	M6	24.0	41.0	4.5	5.5	AG	
	60.0	75.0	M5	24.0	41.0	4.5	5.5	AH	
	60.0	90.0	M5	24.0	41.0	4.5	5.5	AI	
	70.0	90.0	M5	26.0	43.0	5.5	7.5	AJ	
	70.0	90.0	M5	28.0	45.0	5.5	9.5	AK	
	73.1	98.5	M5	24.0	41.0	4.5	5.5	AM	
	73.1	99.0	M6	24.0	41.0	4.5	5.5	AN	
	50.0	95.0	M6	25.0	42.0	5.5	6.5	AO	
	50.0	100.0	M6	25.0	42.0	5.5	6.5	AP	
	60.0	99.0	M6	24.0	41.0	4.5	5.5	AR	
	70.0	90.0	M5	24.0	41.0	4.5	5.5	AS	
	70.0	90.0	M6	24.0	41.0	4.5	5.5	AT	
	80.0	100.0	M6	24.0	41.0	4.5	5.5	AU	
	95.0	115.0	M8	24.0	41.0	4.5	5.5	AV	
	95.0	130.0	M8	24.0	41.0	4.5	5.5	AW	

Version
0

Backlash	Backlash Code
Standard	A

Output shaft	Form Code
Plain	0
Keyed	1

i	Ratio Code
3*	003
4	004
5	005
7	007
9**	009
10*	010
16	016
20	020
25	025
28	028
35	035
40*	040
49**	049
50*	050
70*	070
100	100

\*Not for PGE 12

\*\* Only for PGE 12



Size	Size Code
PGE 12/1, PGE 12/2, PGE 12/3	001
PGE 25/1, PGE 25/2, PGE 25/3	002
PGE 50/1, PGE 50/2, PGE 50/3	005
PGE 100/1, PGE 100/2, PGE 100/3	010
PGE 200/1, PGE 200/2, PGE 200/3	020
PGE 500/1, PGE 500/2, PGE 500/3	050

Size	D6 [mm]	Motor Shaft Code
PGE 12	3	A
	4	B
	5	C
	6	D
	7	E
	8	F
	9	G
	10	H
	11	I

Size	D6 [mm]	Motor Shaft Code
PGE 25	6	A
	7	B
	8	C
	9	D
	10	E
	11	F
PGE 50	12	G
	14	H

Size	D6 [mm]	Motor Shaft Code
PGE 100	9	A
	10	B
	11	C
	12	D
	14	E
	15	F
	16	G
	19	H

Size	D6 [mm]	Motor Shaft Code
PGE 200	14	A
	15	B
	16	C
	19	D
	22	E
	24	F

Size	D6 [mm]	Motor Shaft Code
PGE 500	19	A
	22	B
	24	C
	28	D
	32	E

Size	D6 [mm]	Motor Shaft Code
PGE 1200	22	A
	24	B
	28	C
	32	D

Size	D7 [mm]	D8 [mm]	D9 [mm]	L6 min [mm]	L6 max [mm]	L7 [mm]	L22 [mm]	Flange-Code
PGE 100	50.0	95.0	M6	28.0	52.0	6.5	7.5	AA
	50.0	100.0	M6	28.0	52.0	6.5	7.5	AB
	60.0	75.0	M5	27.0	51.0	5.5	6.5	AC
	60.0	99.0	M6	27.0	51.0	5.5	6.5	AD
	70.0	90.0	M5	27.0	51.0	5.5	6.5	AE
	70.0	90.0	M6	27.0	51.0	5.5	6.5	AF
	80.0	100.0	M6	27.0	51.0	5.5	6.5	AG
	95.0	115.0	M8	27.0	51.0	5.5	6.5	AH
	95.0	130.0	M8	27.0	51.0	5.5	6.5	AI
	110.0	130.0	M8	27.0	51.0	5.5	6.5	AJ
	110.0	130.0	M8	38.0	62.0	7.0	17.5	AK
	110.0	145.0	M8	45.0	69.0	7.0	24.5	AL
	110.0	165.0	M10	38.0	62.0	7.0	17.5	AM
	80.0	100.0	M6	45.0	69.0	7.0	24.5	AN
	95.0	115.0	M8	45.0	69.0	7.0	24.5	AO
	95.0	115.0	M8	31.0	55.0	7.0	10.5	AP
95.0	115.0	M6	27.0	51.0	5.5	6.5	AQ	
50.0	70.0	M4	27.0	51.0	5.5	6.5	AR	
PGE 200	95.0	115.0	M8	30.0	63.0	6.5	8.5	AA
	95.0	130.0	M8	30.0	63.0	6.5	8.5	AB
	110.0	130.0	M8	30.0	63.0	6.5	8.5	AC
	110.0	145.0	M8	30.0	63.0	6.5	8.5	AD
	110.0	145.0	M8	40.0	73.0	10	18.5	AE
	110.0	145.0	M8	45.0	78.0	10	23.5	AF
	110.0	165.0	M10	30.0	63.0	6.5	8.5	AG
	130.0	165.0	M10	40.0	73.0	10	18.5	AH
	80.0	100.0	M6	30.0	63.0	6.5	8.5	AI
	130.0	215.0	M12	30.0	63.0	6.5	8.5	AJ
70.0	90.0	M5	30.0	63.0	6.5	8.5	AK	
PGE 500	110.0	145.0	M8	30.0	63.0	6.5	8.5	AA
	110.0	145.0	M8	36.0	69.0	12.5	14.5	AB
	110.0	165.0	M10	30.0	63.0	6.5	8.5	AC
	114.3	200.0	M12	30.0	63.0	6.5	8.5	AD
	114.3	200.0	M12	50.0	83.0	12.5	28.5	AE
	130.0	165.0	M10	30.0	63.0	6.5	8.5	AF
	130.0	165.0	M10	36.0	69.0	12.5	14.5	AG
	130.0	215.0	M12	30.0	63.0	6.5	8.5	AH
	180.0	215.0	M12	30.0	63.0	6.5	8.5	AI
	180.0	215.0	M12	50.0	83.0	12.5	28.5	AJ

Version
0

Backlash	Backlash Code
Standard	A

Output shaft	Form Code
Plain	0
Keyed	1

i	Ratio Code
3*	003
4	004
5	005
7	007
9**	009
10*	010
16	016
20	020
25	025
28	028
35	035
40*	040
49**	049
50*	050
70*	070
100	100

\*Not for PGE 12

\*\* Only for PGE 12

**ZF Maschinenantriebe GmbH**  
Ehlersstrasse 50  
88046 Friedrichshafen/Germany  
Telefon: +49(0)7541-77-0  
Telefax: +49(0)7541-77-3470  
e-Mail: [industrial-drives@zf.com](mailto:industrial-drives@zf.com)  
Internet: <http://industrial-drives.zf.com>

