

MP2100 - MECHATROLINK-II

PC Motion Controller

PC Based Solution for Advanced Motion Control

- Up to 32 axes controlled with minimum wiring
- Motion APIs are available for customised Control Applications. Motion Commands can be input from either the PC application or the MP2100 program
- Self configuration of nodes for an easy setup
- Supports Position, speed and Torque control
- Electronic CAM profiles and axes synchronization
- The High-speed bus MECHATROLINK-II is specially designed for Motion Control
- Support for I/Os locally and over the network
- Access to the complete system from one point

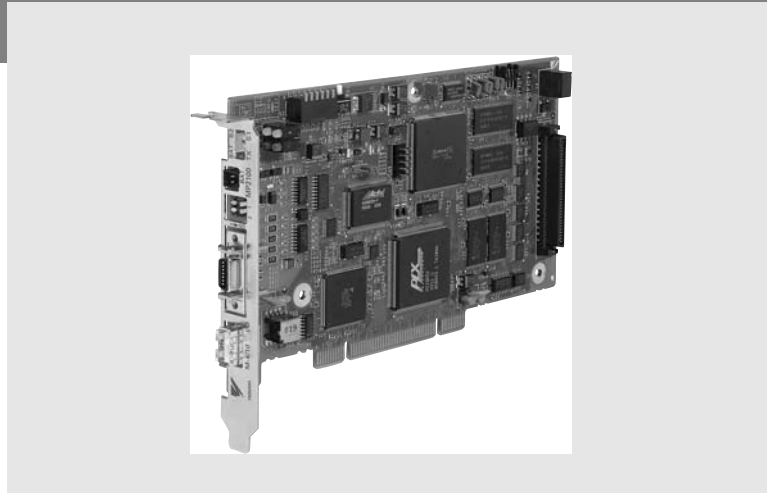

System Configuration

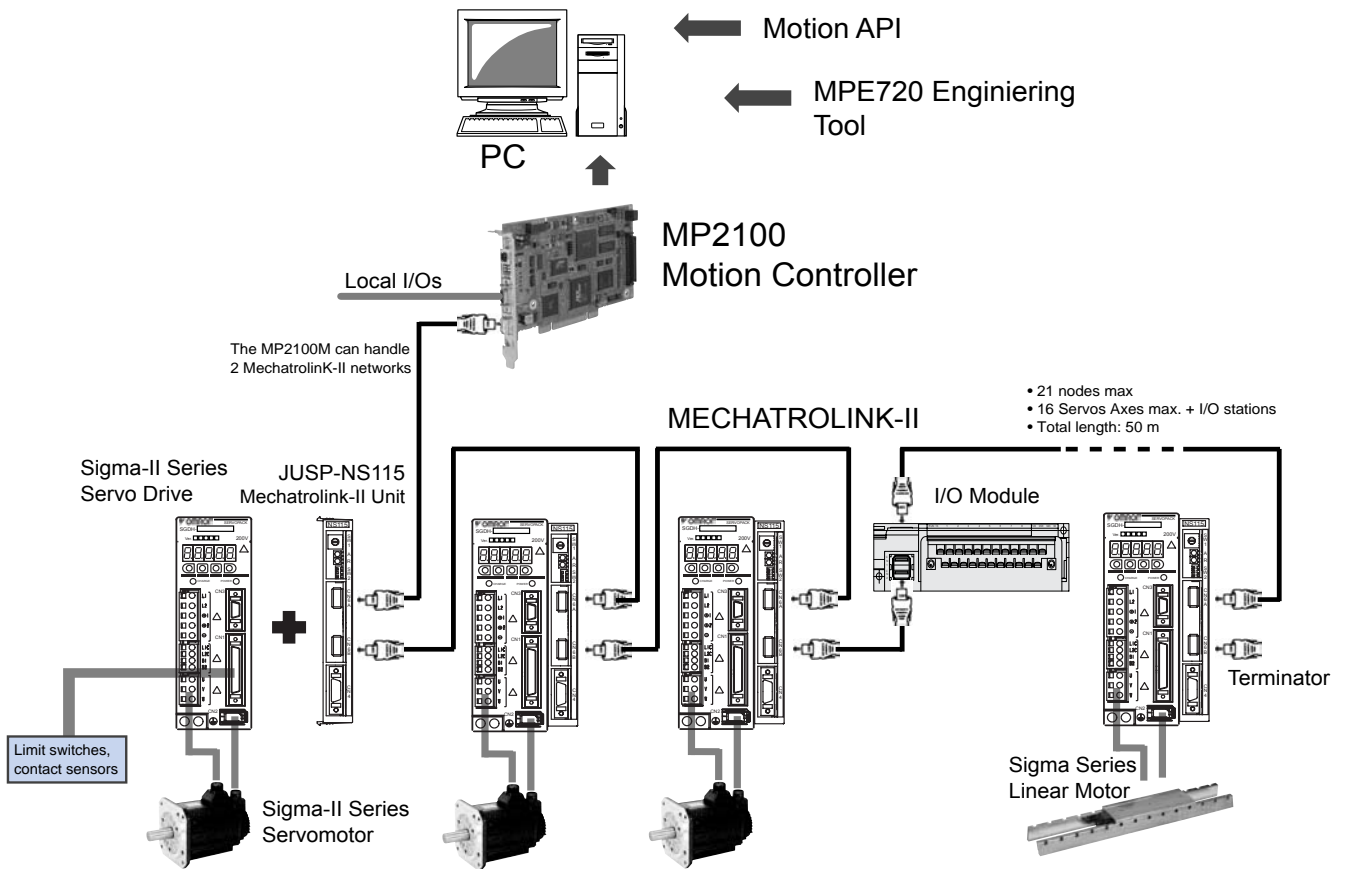

Specifications

General Specifications

Hardware Specifications

Items	Specifications	
Environmental Conditions	Ambient Operating Temperature	0 to 55 °C
	Ambient Storage Temperature	-25 to 85 °C
	Ambient Operating Humidity	30% to 95% (with no condensation)
	Ambient Storage Humidity	5% to 95% (with no condensation)
	Pollution Level	Pollution level 1 (conforming to JIS B 3501)
	Corrosive Gas	There must be no combustible or corrosive gas.
	Operating Altitude	2,000 m above sea level or lower
Mechanical Operating Conditions	Vibration Resistance	Conforming to JIS B 3502: 10 to 57 Hz with single-amplitude of 0.075 mm 57 to 150 Hz with fixed acceleration of 9.8 m/s ² 10 sweeps each in X, Y, and Z directions (sweep time: 1 octave/min)
	Shock Resistance	Conforming to JIS B 3502: Peak acceleration of 147 m/s ² (15 G) twice for 11 ms each in the X, Y, and Z directions
Electrical Operating Conditions	Noise Resistance	Conforming to EN 61000-6-2, EN 55011 (Group 1, Class A) Power supply noise (FT noise): 2 Kv min., for one minute Radiation noise (FT noise): 1 Kv min., for one minute Ground noise (impulse noise): 1 Kv min., for 10 minutes Electrostatic noise (contact discharge method): 4 Kv min., 10 times
Installation Requirements	Ground	Ground to 100 Ω max.
	Cooling Method	Natural cooling

Sequential Function Specifications.

Items	Specifications	
Control Method	Sequence: High-speed and low-speed scan methods	
Programming Language	Ladder diagram: Relay circuit	
	Text-type language: Numeric operations, logic operations, etc.	
Scanning	Two scan levels: High-speed scan and low-speed scan High-speed scan time setting: 1 to 32 ms (Integral multiple of MECHATROLINK communication cycle) Low-speed scan time setting: 2 to 300 ms (Integral multiple of MECHATROLINK communication cycle)	
User Drawings, Functions and Motion Programs	Startup drawings (DWG.A): Interrupt processing drawings (DWG.I): High-speed scan process drawings (DWG.H): Low-speed scan process drawings (DWG.L): Number of steps: User functions: Motion programs: Revision history of drawings and motion programs Security function for drawings and motion programs	64 drawings max. Up to three hierarchical drawing levels 64 drawings max. Up to three hierarchical drawing levels 200 drawings max. Up to three hierarchical drawing levels 500 drawings max. Up to three hierarchical drawing levels Up to 1,000 steps per drawing Up to 500 functions Up to 256
Data Memory	ommon data (M) registers: System (S) registers: Drawing local (D) registers: Drawing constant (#) registers: Input (I) registers: Output (O) registers: Constant (C) registers:	64 Kwords 8 Kwords Up to 16 Kwords per drawing Up to 16 Kwords per drawing 5 Kwords (including internal input registers) 5 Kwords (including internal output registers) 16 Kwords
Trace Memory	Data trace: 128 Kwords (32 Kwords × 4 groups), 16 points defined	
Memory Backup	Program memory: Flash memory: 8 MBytes (User area: 5.5 MBytes) definition files, ladder programs, motion programs, etc. Data other than battery backup data Data memory: Battery backup: 256 Kbytes, M registers, S registers, alarm history, trace data	
Data Types	Bit (relay): Integer: Double-length integer: Real number:	ON/OFF -32768 to +32767 -2147483648 to +2147483647 ± (1.175E-38 to 3.402E+38)
Register Designation Method	Register number: Symbolic designation:	Direct designation of register number Up to 8 alphanumeric characters (up to 200 symbols per drawing) With automatic number or symbol assignment

Motion Control Function Specifications.

Item		Specifications	
Interface		MECHATROLINK-I, MECHATROLINK-II	
Number of Controlled Axes/Module		Up to 16 axes	
Control Specifications	PTP Control	Linear, rotary, and infinite-length	
	Interpolation	Up to 16 linear axes, 2 circular axes, and 3 helical axes	
	Speed Reference Output	Yes (Only with MECHATROLINK-II)	
	Torque Reference Output	Yes (Only with MECHATROLINK-II)	
	Phase Control	Yes (Only with MECHATROLINK-II)	
	Position Control	Positioning	Yes
		External positioning	Yes
		Zero point return	Yes
		Interpolation	Yes
		Interpolation with position detection function	Yes
JOG operation		Yes	
STEP operation		Yes	
Parameter changes during motion command execution	Yes (Only with MECHATROLINK-II in 32-byte mode)		
Reference Unit	mm, inch, deg, or pulse		
Reference Unit Minimum Setting	1, 0.1, 0.01, 0.001, 0.0001, 0.00001		
Maximum Programmable Value	-2147483648 to +2147483647 (signed 32-bit value)		
Speed Reference Unit	Reference unit/s designation: mm/s, inch/s, deg/s, pulse/s Reference unit/min. designation: mm/min, inch/min, deg/min, pulse/min Percentage designation: Percentage of rated speed		
Acceleration/Deceleration Type	Linear, asymmetric, S-curve, exponent		
Acceleration/Deceleration Reference Unit	Reference unit/s ² designation: mm/s ² , inch/s ² , deg/s ² , pulse/s ² Acceleration/deceleration time constant: Time from 0 to rated speed (ms)		
Override Function	Positioning: 0.01% to 327.67% by axis		
Coordinate System	Rectangular coordinates		
Zero Point Return	DEC1+ Phase-C pulse	Yes	
	ZERO signal	Yes	
	DEC1+ ZERO signal	Yes	
	Phase-C pulse	Yes	
	Only Phase-C pulse	Yes	
	POT and Phase-C pulse	Yes	
	POT	Yes	
	Home limit switch and Phase-C pulse	Yes	
	HOME	Yes	
	NOT and Phase-C pulse	Yes	
	NOT	Yes	
	INPUT and Phase-C pulse	Yes	
INPUT	Yes		
Applicable Servo Drives	SGDH-□□□E-OY + NS115		
Encoders	Incremental Encoder Yaskawa Absolute Encoder		

MP2100, MP2100M Boards

Items		Specifications	Appearance
Model		JAPMC-MP2100, JAPMC-MC2140	
Power Supply		Input supply voltage: 5VDC±5%	
Dimensions		106.68X174.63mm Half the size of a standard PCI	
Motion Network		MECHATROLINK-II: One channel with MP2100, two channels with MP2100M Twenty-one stations, including servo drives and I/O equipment, can be connected. (16 axes for servo drives) Transmission speed: 10Mbps (MECHATROLINK-II) Transmission distance: See "MECHATROLINK-II Repeater"	
I/O Signals		Digital input: 5 points (One point can be used for interrupts), 24VDC, 4mA, and source mode or sink mode input Digital output: 4 points, 24VDC, 100mA, open collector, and sink mode output	
Electrical Operating Conditions	Noise Resistance	Radiation noise (FT noise): 1kV or more for 1 min. Static noise (contact discharging method): 6kV or more for 10 times Other noise: Not specified	
	Mechanical Operating Conditions	Vibration Resistance	
Shock Resistance		Not specified	
Installation Requirements	Ground	Follows the personal computer's requirements	
Environmental Conditions		Same as the general specifications	

Host computer specifications

Items		Specifications
Hardware	Model	PC/AT compatible
	CPU	Pentium 200 MHz or more (Pentium 400 MHz or more recommended)
	Memory Capacity	64 MB or more
	Hard Disk Drive Capacity	Free space 500 MB or more
	Display Resolution	800X600 or more (1024X768 recommended)
	Expansion Slot ¹	Half the size of a standard PCI slot
	Interrupts ¹	First-level use (IRQ sharing is possible)
Software	I/O Memory ¹	32 kB shared memory used
	OS	Windows NT 4.0 Workstation SP5 or later Windows 2000 Professional SP1 or later Windows XP
	Web Browser	Microsoft IE 5.5 SP2 or later
	Language	Microsoft Visual C/C++ 6.0 SP5 or later

1.: These specifications are applicable if using one MP2100s board. If using two or more boards in the same host personal computer, Expansion Slots, Interrupts and I/O memory resources needs to be increased per each board.

Mechatrolink-II, 64 Point I/O Module (IO2310)

Items	Specifications	Appearance
Model	JEPMC-IO2310	
I/O Signals	Input: 64 points, 24VDC, 5mA, sink/source mode input Output: 64 points, 24VDC, 50mA when all points ON,(The Max. rating is 100mA per point) sink mode output (NPN) Signal connection method: Connector (FCN360 series)	
Module Power Supply	24VDC (20.4V to 28.8V) Rated current: 0.5A Inrush current: 1A	
Weight	590 g	

Mechatrolink-II, Counter Module (PL2900)

Items	Specifications	Appearance
Model	JEPMC-PL2900	
Number of Input Channels	2	
Functions	Pulse counter, notch output	
Pulse Input Method	Sign (1/2 multipliers), A/B (1/2/4 multipliers), UP/DOWN (1/2 multipliers)	
Max. Counter Speed	1200kpps (4 multipliers)	
Pulse Input Voltage	3/5/12/24VDC	
External Power Supply	For input signal: 24VDC, For dividing load: 24VDC, For module: 24VDC (20.4V to 26.4V), 120mA or less	
Weight	300 g	

Mechatrolink-II, Pulse Output Module (PL2910)

Items	Specifications	Appearance
Model	JEPMC-PL2910	
Number of Output Channels	2	
Functions	Pulse positioning, JOG run, zero-point return	
Pulse Output Method	CW, CCW pulse, sign	
Max. Output Speed	500kpps	
Pulse Output Voltage	5VDC	
Pulse Interface Circuit	Open collector output 5VDC, 10mA/circuit	
External Control Signal	Digital input: 8 points/module, 5VDC x 4points, 24VDC x 4points Digital Output: 6 points/module, 5VDC x 4 points, 24VDC x 2 points	
Weight	300 g	

Mechatrolink-II, Analog Input Module (AN2900)

Items	Specifications	Appearance
Model	JEPMC-AN2900	
Number of Input Channels	4	
Input Voltage Range	-10V to +10V	
Input Impedance	1MΩ min.	
Data Format	Binary, -32000 to +32000	
Input Delay Time	4ms max.	
Error	± 0.5% F.S. (at 25°C), ± 1.0% F.S. (at 0°C to 60°C)	
External Power Supply	24VDC (20.4VDC to 26.4VDC), 120mA max.	
Weight	300 g	

Mechatrolink-II, Analog Output Module (AN2910)

Items	Specifications	Appearance
Model	JEPMC-AN2910	
Number of Output Channels	2	
Output Voltage Range	-10V to +10V	
Max. Allowable Load Current	± 5mA (2kΩ)	
Data Format	Binary, -32000 to +32000	
Output Delay Time	1ms	
Error	± 0.2% F.S. (at 25°C), ± 0.5% F.S. (at 0°C to 60°C)	
External Power Supply	24VDC (20.4VDC to 26.4VDC), 120mA max.	
Weight	300 g	

Mechatrolink-II Repeater

Items	Specifications	Appearance
Model	JEPMC-REP2000	
Communication Type	MECHATROLINK-II	
Cable Length	Between controller and repeater: 50m., after repeater: 50m	
Max. Connected Stations	Total stations on both sides of repeater: 30 (Limited to the max. number of connectable stations of the controller (e.g., 21 stations for the MP2300 series))	
Restrictions	Between controller and repeater - Total cable length ≤ 30m: 15 stations max. including I/O and servo, etc. - 30m < total cable length ≤ 50m: 14 stations max. including I/O and servo, etc. After repeater: - Total cable length ≤ 30m: 16 stations max. including I/O and servo, etc. - 30m < total cable length ≤ 50m: 15 stations max. including I/O and servo, etc.	
Power Supply	24VDC, 100mA	
Weight	340 g	
Dimensions (mm)	160 x 30 x 77 (W X H X D)	

Mechatrolink-II Servo Drive Interface Unit

Item	Details		
Type	JUSP-NS115		
Applicable Servo Drive	SGDH-□□□E models (Version 38 or later)		
Installation Method	Mounted on the SGDh Servo Drive side: CN10.		
Basic Specifications	Power Supply Method	Supplied from the Servo Drive control power supply.	
	Power Consumption	2 W	
MECHATROLINK-II Communications	Baud Rate / Transmission Cycle	10 MHz / 500 ms or more. MECHATROLINK-II communications (4 MHz / 2 ms for MECHATROLINK-I communications)	
Command Format	Operation Specification	Positioning using MECHATROLINK-I/II communications.	
	Reference Input	MECHATROLINK-I/II communications Commands: Motion commands (position, speed), Interpolation commands, Parameter read/write, Monitor output	
Position Control Functions	Acceleration/Deceleration Method	Linear first/second-step, asymmetric, exponential, S-curve	
	Fully Closed Control	Position control with fully closed feedback is possible.	
Fully Closed System Specifications	Fully Closed Encoder Pulse Output	5 V differential line-driver output (complies with EIA Standard RS-422A)	
	Fully Closed Encoder Pulse Signal	90° Phase difference 2-phase differential pulse (phase A, phase B)	
	Maximum Receivable Frequency for Servo Drive	1 Mpps	
	Power Supply for Fully Closed Encoder	To be prepared by customer.	
Input Signals	Signal Allocation Changes Possible	Forward/reverse run prohibited, Zero point return deceleration LS External latch signals 1, 2, 3 Forward/reverse torque control	
Internal Functions	Position Data Latch Function	Position data latching is possible using phase C, and external signals 1, 2, 3	
	Protection	Parameters damage, Parameter setting errors, Communications errors, WDT errors, Fully closed encoder detecting disconnection	
	LED Indicators	A: Alarm, R: MECHATROLINK-I/II Communicating	

Dimensions

MP2100, MP2100M Boards

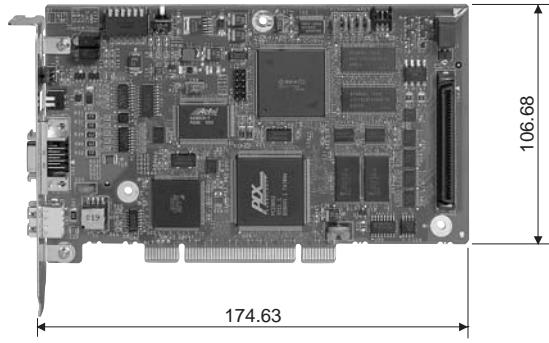

IO2310 I/O Module

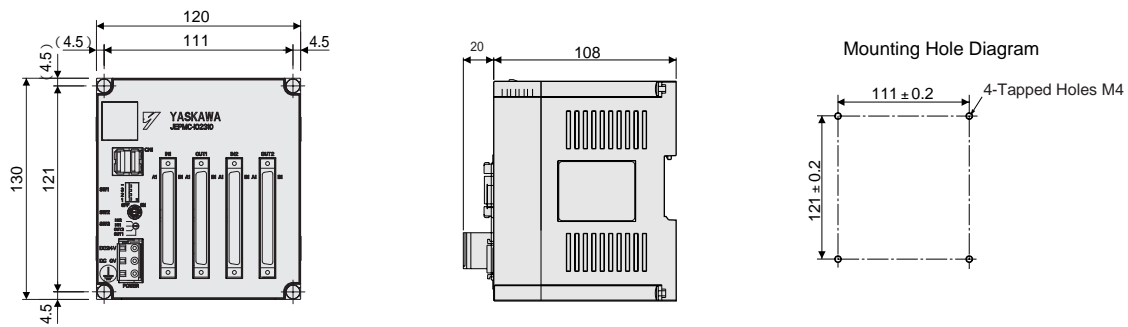

I/O Modules PL2900, PL2910, AN2900, AN2910

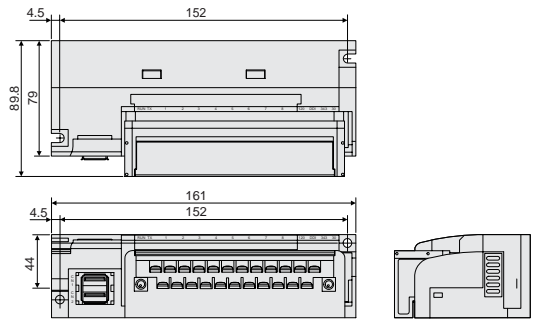

Mechatrolink-II Servo Drive Interface Unit

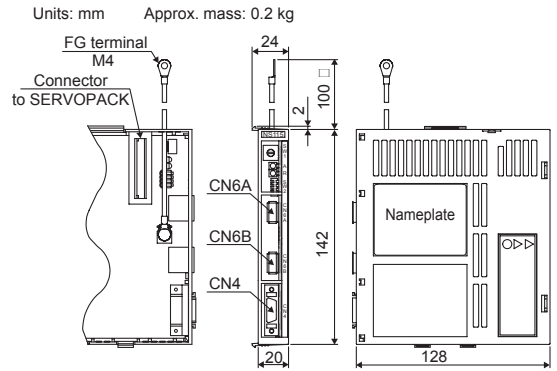

Ordering Information

MP2100 - Motion Controller Main Units

Name	Model Name	Model
MP2100 board, 1 channel for MECHATROLINK-II communication, 5-point input and 4-point output	MP2100	JAPMC-MC2100
MP2100M board, 2 channels for MECHATROLINK-II communication, 5-point input and 4-point output	MP2100M	JAPMC-MC2140

Mechatrolink-II - Related devices

Name	Remarks	Model
Distributed I/O Modules	64-point input and 64-point output	JEPMC-IO2310
	Reversible counter: 2 channels	JEPMC-PL2900
	Pulse output: 2 channels	JEPMC-PL2910
	Analog input: -10V to +10V, 4 channels	JEPMC-AN2900
	Analog output: -10V to +10V, 2 channels	JEPMC-AN2910
Mechatrolink-II Cables	0.5 meter	JEPMC-W6003-A5
	1 meter	JEPMC-W6003-01
	3 meters	JEPMC-W6003-03
	5 meters	JEPMC-W6003-05
	10 meters	JEPMC-W6003-10
	20 meters	JEPMC-W6003-20
	30 meters	JEPMC-W6003-30
Mechatrolink-II Terminator	Terminating resistor	JEPMC-W6022
Mechatrolink-II Interface Unit	For Sigma-II series Servo drives. (Firmware version 38 or later)	JUSP-NS115
Mechatrolink-II Repeater	Mechatrolink-II Repeater	JEPMC-REP2000

I/O Cables

Name	Remarks	Length m	Model
I/O Cable for MP2100	With connector on the MP2100 side	0.5	JEPMC-W2062-A5
		1.0	JEPMC-W2062-01
		3.0	JEPMC-W2062-03
I/O Cable for IO2310	With connector on the IO2310 side	0.5	JEPMC-W5410-05
		1.0	JEPMC-W5410-10
		3.0	JEPMC-W5410-30

Accessories

Name	Model
Battery ER3V 3.6V	JZSP-BA01
Extended Cable for Battery with connectors on both sides	JEPMC-W2090-01

Computer Software

Specifications	Model
Programming software to support from system design to maintenance. Intuitive ladder programming and editing functions. CAM data generation Windows-based (Windows 95/98/NT4.0/2000/XP)	CPMC-MPE720
Motion API. Header file, library, DLL, driver, and manual	CPMC-MPA70

Servo system

Note: Refer to Sigma-II Series documentation for detailed information